

Rowe CBA, CBA-2 UCBA-2
CBA-4 and UCBA-4s

An overview By Bruno D Puglia

March 10, 2005

East Coast Amusements

Canton, MA

<http://www.eastcoastamusements.com/>

This is another BEARNOTE written
to help keep your operating costs
down and profits up!

IN 2005, I still get many CBAs to be repaired and rebuilt. Many vendors who had elected not to update to the new \$5 bill are electing to update the units to accept the new \$5.

It don't work.... What can I do?

These notes deal with CBA/UCBA type acceptors. If you contemplate working on CBA/UCBAs acceptors, you must browse through the manuals. I advocate you read my "The Magic Wand Oilier" notes. Some of you will disagree with the ideas I will present, but this is ok. It is not a question of right or wrong, but an alternate perception provided you are willing to keep an open mind. Those who say; "Leave it alone until breaks" will disagree with me a great deal of the time. It is your extra \$ which will be expended, not mine!

Warning: There is one exception where you can break something! I have to be honest with you there is one area where you can break something and be left with an acceptor that is in real trouble. This area is the lower cell board and those clips that hold it in place. The design is not the best in the world, well maybe the design was but it ended up that one of the clips would break off when attempting remove or put the board back into place. You have to read the manual and learn to be very careful when removing or installing the board. Even with extreme care that the clip may break so you had better have a spare acceptor handy. Do you have to take it off? I think the answer is

yes for many reasons. To clean the V2 and V3 cell and V2/3 LED. To see the hole for V3 and maybe clean out debris stuck inside the acceptor. History has shown you may have to replace the LED or cell, or even the entire board. The wire leads and connections may be broken or bad and you may find it is easier to replace to entire assembly. For those who can replace belts and work on CBA-2, UCBA-2, and CBA/UCBA-4s you might want to stock a lower track assembly so you can replace it when the clip breaks. I would be remiss in not telling you about this breakage problem before I ask you to clean and work on these acceptors. Follow the manuals instruction and pray the clip does not break!

I have been told my notes were too mild! From my prospective, I have put constrains on myself when writing these documents. Sometimes, people think freebees, like these notes, are going to cost something! That is not the case, but you will have to spend the time it takes to read the notes. I challenge you to discover how much the notes will save you in time, money, and stress!

Towards the end of these notes I will talk about vendor denial and point out cases where people missed the boat. They wasted both time and money. In the mean while keep an open mind set when reading these notes and let the information sink in. These notes contain information on the big picture and at the same time has many details you need to become an expert CBA-UCBAer.

Today, paying out more money seems to be the answer for resolving major problems. You know, keep raising our taxes so there is more money in the budget so they can spend more. Expending more money does not solve all the problems does it? Are you running your business like our government is run? There are better ways of doing things, but do you have to be astute enough to find and use them. I have no way to knowing what level of CBA/UCBA-ing you are at this time. I presume you will know more when you are done reading these

notes. I also presume you will not want to change your order of things and there are valid reasons why you do not want to try something new. I presume you want the quick, cheap fixes and this is ok but you already know this is not what goes on in the real world of vending. This leaves us at a deadlock or does it? Life without something new sucks. However painful, something new like CBA/UCBA-ing, can have its reward in terms of money and even more in terms of self-esteem. From my notes Basics 101, "Being at risk can be fun." Are you ready to be at risk and try your hand at CBA-ing?. If I say regular lubrication of an acceptor can increase the life by 2x, 3x, 4x, more I ask you to consider the statement's worth. Working on a CBA/UCBA which is in a failure mode is not the same as doing scheduled preventive lubrication. If you wait for a full failure mode chances are the CBA/UCBA life is already shorten by 2x or 3x, maybe even more. You would not run your car without oil in it because you know any damage done will be permanent

Your order of doing things is your style and I would not presume I am going to change it. I will say when trouble reports are made with details and with error messages or status on, off, or number of blink reports, the play on comments back and forth is expanded between us and all of us learn. We both end up one more step ahead of the game. The base of knowledge is expanded and problems become a lot easier to handle. These notes deal with the actual repair or rebuilding of the CBA/UCBA because many people have asked for specific information at one time or another. Most of you will wait for a full failure before attempting to do even a simple lube job in hopes of fixing the unit and getting it back on line. The odds of this are against you because other problems may exist. If your car engine has burned up, adding more oil is not going to fix the engine damage. Without oil your CBA parts which may have reached the failure mode. Perhaps the head, pressure roller, belts, motor, tracks, etc, may need replacing. In these notes you may find a short term quick fix but these notes were written with long

term life preventive maintenance in mind rather than quick fixes. The real big long-term pay back does not come from on demand quick fixes when the unit fails. My Magic Wand is the Magic Wand Oilier and a little common sense; Keep it clean and oiled. By the time you decide to lube the acceptor you may be to late. Bad rollers, bad connections, bad interconnects, bad belts, bad motor, damaged motor/gear, dirt in pulley areas, bent shafts, bad cells or LEDs, etc, problems may already exist and the oiler will not fix these items. Remember every rejected bill is worst then an accept of a bill in terms of wear and tear. The snap reverse action this puts extra strain on the acceptor and the reject counts as another pass of a bill. If the acceptor is rejecting bills, a person may insert a bill several times thus you end up with 14 passes without accepting a single bill. The stress of running without lubrication will take its toll in wear and this is like driving your car with no oil in the crankcase. There is no grace period when it comes to lack of lubrication!

Lets look at one failure mode. Perhaps the acceptor needed lubrication, but the magnetic head is bad. The acceptor acceptance rate as fallen of to a point where lubrication will never restore the acceptor to a good acceptance level. Even worst, you may have attempted to change the belts, etc, and cannot get the unit to work. This is a sad story. You may have done every thing right and it still does not work correctly. Remember you waited for the failure mode and you do not have a way to test the head to find it if the head is bad before you re-assemble the CBA. You have to put it back together to find out if it is going to work. Maybe the acceptance rate is only acceptance of 6 out of 10 bills. The 4 rejects a much higher percentage of wear and tear then you think since rejected bills was one pass into and one pass out of the acceptor. It accepted 6 bills, but there was almost 8 full passes over the head for the 4 rejected bills. That is 8 wasted passes, or a shorten life of 8 bills, not 4. At this point, this is a 8:6 ratio not 4:6. Lets carry this to reality. A customer may try to put a bill into the

acceptor several (7) times and it never is accepted, or if it does, that is 13:1. This is 13 extra passes over the head. What I find is acceptors that are not cleaned and lubricated may need magnetic head replacement. To fix the acceptor, you have put in a new head and who knows what else. This is your pay back, or should I say pay out for not cleaning and lubricating the acceptor long before the full failure. Do you still think you can beat the odds?

When do we change a CBA/UCBA Magnetic head assembly? I use a special Bruno Magnetic Head & amplifier test. If fails the test, or the magnetic head is on the way out (weak), the head assembly is replaced. My magnetic head test is not concerned with the other factors of bad acceptance like the motor, belts, tracks, path, belt tensions, pressure roller and springs, cells and LEDs, etc. The test is not a guess or an assumption. It is not subject to misleading results due to poor or bad bills. Before I got into vending, I worked in other electronic fields and this background allowed me to work with the man who made the first magnetic test tape for the National Bureau of Standards. With of this valuable experience I was able to design and implement the Bruno Magnetic head-amplifier test that puts a figure of merit overall on the head assembly. It actively tests several parameters of the CBAs magnetic head and its amplifier. Electronics, wear, and/or life, cannot be evaluated by visual inspection alone. Accepting 10, or even a 100 bills does not mean the head will be ok in a few months down the road. Once head failures start, the number of rejects can increase very quickly.

In a check of 98 CBA-2 and UCBA-2 acceptors repaired in early 1994, 30 needed head assembly replacement. Most serial numbers were in the range of 400,000 to 600,000. The early 1994 replacement figure (~30%) is running higher then it did in the last the part of 1993 that ran about 24 %. All of this is not to say a low serial number unit must get a new head. That is not the case. It is just that some of the older acceptors got a

lot of use, and/or even worst, rejected a lot of bills, so they end up with a bad or or sub-standard magnetic heads. This is why lubrication and cleaning of the acceptor is so important. Reject bill passes back and forth over the head means a shorter head, belt, shaft and motor life. Vendors who runs their acceptors into the ground end up with a higher head replacement percentage but be assured the TEST ensures good heads will not be needlessly replaced. The test also finds those heads that will have to be replaced in the near term. If you do not replace a sub-standard head up front, you will find less money in the bill box, be putting extra wear and tear on the acceptor, and you have to get another repair to replace the Magnetic head assembly. When do we change a magnetic head assembly? Most of you will speculate there is a grace period when the unit is new. This is wishful thinking. The new finish on the shafts does keep the CBA running for a short period. Without the lubrication the shaft coatings will wear. Once the coatings start to wear, it is like a vinyl roof on your car that starts to crack and peel. No amount of cleaning, or protection is going to restore the roof and it will continue to crack and peel. In the CBA, the scalings inside the rollers become a cutter and it increases the cutting action. This is much worst then the car roof illustration above. By now, you should see its important to start lubrication when the acceptor is new rather then waiting till it slows down. Sorry, there is no grace period!

Ok let's look at some history. Three CBA-2 were serviced in 1989 and at the end of 1991. They had been cleaned and lubricated. In the early part of 1995, these three acceptors came in for repair again however this time many parts were worn, the magnetic heads were shot and the motors were in bad shape too. These acceptors would hardly pull the bill into the acceptor. To say they had stickation would be wrong. They had stuckation. This time the vendors had to go for the nut. The rejection rate must have been very high for months maybe longer. If these acceptors have been lubricated every year, can you

forecast what the conditions of these acceptors today? My mind set tells me I would not have seen them in 1991 nor 1995. That would be double the life and I am sure even more. The service bill would not have been \$ 200.00 to \$300.00 but the cost of one oiler (with quite a bit still left), some cleaner and the time to do the 5 or 6 lubrications. Because the lubrication was not done, you can the loss of income because of stickation and poor, or no acceptance. Remember when I got the three acceptors they would not accept a single bill!

We now will get into scheduling and why the time to start was yesterday. For those who do not have spare acceptors and are not doing any preventive maintenance you can anticipate hysteria and down time as a matter of fact. In addition, increased repair costs. BTW: Do you drive around without a spare tire in your car? I do not know about a flat tire, but I do know the acceptor will fail without TLC cleaning and lubrication!

Try this question; When was the last time you cleaned and lubricated a CBA/UCBA, after you started having problems? You do not have to answer because the CBA CBA-2 or UCBA-2 will end up in the repair shop sooner or later. In the case of no lubrication, a lot sooner! Think about this repair bill: CBA-2 with bad motor, bad module logic, bad upper drive shaft, bad input shaft/rollers, plus worn belts etc. When your acceptor hits the shop, (yours, someone or mine elses), it will need just a cleaning and lube or major part replacements?

Before getting in to deep, you have to know what type acceptor you have. You have to look at and acceptor and determine which type of acceptor it. "CBA", "CBA-2", "UCBA" "C/UCBA-4" alone is not good enough. The label may not be accurate. A UCBA-2 might be marked CBA-2. CBA/UCBAs can be retrofitted into equipment and the acceptor can be retrofitted with various logic modules, transformer power supplies, kits, etc, so there is no list which will cover all the special cases. Because transformers can be removed, swapped, installed, inlets

changed, or modules exchanged with the new upside version the model number means very little. You have to tell us which CBA/UCBA unit you have or need. As one example, the CBA-2 or UCBA can be married with an OEM Kit to a coin mech and you now have a replacement for the COINCO type single price setup. A breakdown listed below will allow the user to "name the acceptor".

The following is a general breakdown of CBA/UBA-2s units. .

=====

Over the years, there have been several different logic modules. Some are specific versions and others are new updates of older modules. The number of the logic module is as important as the CBA or UCBA number. The CBA or UBA might have a given number, but, since the modules may have been changed, the CBA or UCBA number mean very little. The Universal UCBA-2 has the big rectangular inlet (similar to MARs type acceptors). The label is generally marked "CBA-2" so you have to know which one you have by looking at it. The CBA-2 and UCBA-2 are different.

Rowe introduced the locking bill box many years ago and problems can occur if you don't where there are, or not used. Example: a locking bill box CBA-2 will not fit into the R92, 3, 4-jukebox.

CBA: we call it a "CBA-1" The 1st Rowe up-stacker. It is connected to the system via connector-cable located at the bottom of the acceptor that interfaces to a CBA-1B control unit. This cable carries the power from the control unit to the acceptor. We add "-1" to the name so it is not confused with other types of CBA/UCBAs.

This CBA is found in early 448 snacks, early Nostalgic juke boxes and some AP machines (OEM version). Some were in very early 448s has an outboard acceptor and then in the early 488 machines.

CBA-1 with control unit 4-50679-03 is found in some AP/OEM vending machines. Early Nostalgic Juke boxes used a

CBA-1 with a Control unit 4-50679-05 and later with the control unit 448-44502 / 6-50633-0x

On the 448 CBA-1, there is a hinged top plate which is a latch. If you have to swap the top plate, please note the two (2) screws holding the plate are also the belt tension adjustments. When loosening these screws, the assembly drops. This removes the tension on the belts. You will have to re-adjust the belt tension.

Here is a list for CBA-2/4, UCBA-2/4s:
Note: Coinco versions of CBA-2 or UBA-2s can have special Coinco logic modules and transformers.

CBA-2 Coinco - special transformer (Jones Plug)
UCBA-2 Coinco - special Transformer (Jones Plug)

=====
There are units with transformers and others without the transformer. Let's see if we can make up a system we can use to tell what kind of unit it is. You will find some units also are label "COINCO". When this occurs, just add the word "COINCO" to the information. While the list looks long its easy to handle. CBA-1, CBA-2/4 or UBA-2/4 and add "Coinco" if marked Coincot = Transformer

The transformer is actually a DC power supply.

NV = New version Plastic shield and upside down module with 8 position dip switch on bottom, not inside.

CBA (1) Connector on bottom, No metal latch cover over the bill box
CBA-448 or CBA (1) /448 Connector on bottom, has a metal latch cover over bill box

The CBA-2/4 is flat along the front
CBA-2 no transformer
CBA-2t with transformer
CBA-2t COINCO with Coinco transformer and "Coinco" version

CBA-2 NV New Version upside down module
CBA-2tNV with transformer and has New Version upside down module

The UBA-2/4 is stepped along the front
UCBA-2 no transformer
UCBA-2t with transformer
UCBA-2 NV with New Version upside down module
UCBA-2tNV with Transformer and New Version upside down module

R92, 3, 4 CBA-2
(Will not take locking bill box.)

Late B, C.D CBA-2 Wall boxes use CBA-2

Switching settings: You must know what the switch settings are for any given setup. Several equipment types use the 2-wire serial data link called Rowelink. These include CD100-B, C, D 4900, newer Nostalgic Junk box (with CBA-2), SBC-2, etc. The switch setting is 1 3, 4 on. Here is where it gets messy. Switches can be set but there must be a new power up or a push of the reset bottom so the new switch settings can be read by the logic board. Another important item is the 2-wire data cable/plug with the new version module (switches on bottom) goes in the plug into the bottom socket near the reset switch and not in the one on the edge of the board. On the older modules with the switch inside under the stacker box, the 2-wire plug goes into the plug on the edge of the module. I cannot count the hours spent on the phone covering switch settings, not pressing reset after setting switches and where the 2-wire plug goes. Re-read this until you understand what has to be done.

Problems relating to acceptors including Stickation.

Generally there is a period of time when the poor acceptance first starts and then the acceptor will not accept any bills. In this pre-fail time frame, you may lose money and may be getting people furious enough to do damage your to the vending machine, game

or acceptor. My daughter told me; "I bring my own because your Rowe machines never accept the money". My wife brings her own can of soda to work because the machine "never works." How much of the loss of sales is due the bad times, or is it because the equipment "never works"? Once people start bringing their own, or find other means of getting product. Their money may never find its way into your vending machine. The wife's and daughter's cans of soda on are the kitchen floor right now and they bring cans to work every day.

If you find the acceptor cash box dollar amount seems to be low, it could be the CBA/UCBA does not accept bills after the acceptor was at rest for a period of time (idle time). The acceptor may not be able to complete the stacker cycle, or the motor driving the belts is too slow, will not start, or get up to speed. The acceptor may accept all bills after it has run for a while, but it may not accept or stack the bill after a period of "shut-down" (non-use - idle time - rest). These kinds of problems could exist when an acceptor is in need of cleaning, lubrication, or when the stacker or drive motor needs replacement. I call this type of problems stickation. This is why you have to watch the stacker and watch/listen to the motors when you first start up the CBA/CUBA.

In case you have not seen other notes I have written, I will get into what happens, as a rule, when a CBA/CUBA is repaired. The preventive maintenance lubrication procedure in the manual has not been preformed in most cases. Removing debris like a bill, etc, is not a full repair since this action only gets the acceptor to the condition it was just before the failure. The reason why someone stuck junk into the CBA or nicked the tracks with a sharp object attempting to get a bill out of an acceptor was that the acceptor was not working correctly to begin with. The damage or stuck object may have been directly related to the lack of cleaning, lubrication, speed or belt adjustment. Which came first, the chicken or the egg? It appears most problems started

with the lack of maintenance and this creates the other problems. Stop and think about it. How often are the CBA/UCBAs taken care of other then a full failure mode? Some people who do use a needlepoint oilier to get a unit running again, but many only do the parts they can see and not the rest of the unit. These CBAs still end up in the shop with a stuck bill or junk inside, maybe with damaged tracks, mag heads or worst. Along the same lines, the upper drive pulley may crack. It appears the forward and reverse action when a bill gets stuck puts quite a bit of strain on the pulley. Generally replacing the pulley alone will not be enough to put the acceptor back in good shape.

A stacker motor may have stickation. When the unit is powered up, or after a period of non-use, the stacker motor is very slow and does not complete the stacker cycle in the allowed time. The acceptor will shut down with the stacker error blink code. Before doing anything, look at the status on the control unit if it is a CBA-1, or status LED on the CBA/UCBA to see what the blink code is. This will tell you if you had stacker problem, or other problems. If you do not look first, it may take months to track the problem down because you can reset it and it will work. After a reset or re-power the unit, it may be loosened up enough for the stacker to continue stack correctly or accept bills until the next non-use period. Another stickation or jam problem might be loose or missing screws that hold the stacker motor in place. If you pull out the stacker to replace the stacker motor, etc, make sure the stacker plate does not pull out the cable/plug going to the magnetic head assembly and create another problem.

////////////////////////////////////*****\////////////////////////////////////

01 [Bear facts on debris stuck inside a CBA or UCBA Acceptor]

by Bruno D Puglia August 06,1993

Problems can occur when debris or bills are stuck inside the acceptor. Debris or bill removal is not a warranty item. Someone may attack the problem by using anything they can get their hands on. All too often,

the tool is sharp, or pointed, and two things can happen when the tool is used. It may be large compared the opening and the acceptor opening is deformed and left open. This affects the way the bill is pulled into the acceptor. In addition, the tracks are nicked or cut by the sharp tool and they have to be replaced. Remember, the upper assembly also contains the magnetic head and the magnetic amp and it is expensive.

How does a person handle junk stuck in the acceptor?

The simplest way to remove junk is to use a semi-stiff piece of Mylar or plastic strip about .020 thick. For those who want make a strip, cut a mylar strip so it just fits in the space between the belts and long enough to reach from the back of the acceptor all the way to the front inlet. To get junk out of the acceptor, kill the power to the acceptor, then open the bill box. We are going implant the strip in the back and push the debris out the front. <KEEP READING>! You must pull or push the anticheat lever so the strip can be inserted into the track openings in the rear. Slowly push the strip and pray whatever is inside the tracks comes out the front. If something is stuck on the edges of the tracks, you may have to repeat the process but this time insert the Mylar between the two belts. You may have to do the left, right, or both sides. You must get the anticheat out of the way before pushing the strip into the tracks.

Another option is removing the acceptor and then remove the logic module and maybe the cover on the bottom. This will gain you access to the lower cell assembly board. Read the manual for instructions of how to remove this sensor board otherwise you can mutilate the lower track clip that holds the cell assembly board. If clip breaks, you have to replace the lower track. Once the sensor board is removed, you can see the hole for the V3 sensor and you might see the debris and be able to remove it. A much larger hole is under the head pressure roller. Do not pull up on the pressure roller assembly because this will deform the springs. Remove both

springs and the pressure roller can be moved out of the way and expose the hole. If Murphy's Law has been repealed, you can pull the junk out of the acceptor.

The mylar or plastic strip procedure presumes the tracks has not been damaged by sharp objects. If a worst-case condition exists and you cannot get the tracks clear, the acceptor has to come apart. Hope you have a spare!

BTW - The Mylar strip is actually a old juke box label strip. They are no longer available.. An alternative might be a plastic bookmark sold in some bookstores. You want to end up with a .020 thick strip that is about 1 5/8" wide x 7 1/2" long.

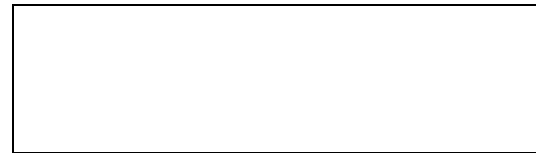

7 1/2" x 1 5/8"

We talked about the magnetic head pressure roller before, so let's talk about removing metal particles which cause poor acceptance. Do not presume you can see the metal particles. They are not always little bright flakes. Some are dark and blend right into the rubber. Aside from replacing the pressure roller, sometimes the particles can be removed by pulling scotch tape over the roller. Keep pressure on the tape as you pull the tape. You have to be careful not to put pressure on the pin and spring that holds the pressure roller assembly in place. You may have to pick the metal particles out of the roller. As last resort, replace the roller assembly. Remove the two springs so you can tape cleaning procedure. Always do this procedure when you are lubricating and cleaning the CBA/UCBA. For the quick fixers, you can make a plastic strip with a slot cut out for a strip of scotch tape to pick up the filings without taking the acceptor apart. You can also make a strip and use double sided tape like Scotch double coated tape #665. How often will you need the procedure is hard to predict. In one case, an acceptor CBA-2 was not accepting bills after

only a week's use. It was cleaned with tape and the owner shown how to clean it with the tape so he could do the procedure himself. After two years, the acceptor was accepting bills and the procedure was never used however, the acceptor did need a good cleaning and lubrication.

Before getting into other problems, let's cover cleaning the belts. Rowe has originally stated only de-natured Alcohol be used to clean the belts and I stick to the statement. Isopropyl alcohol is not an alternative. It dries out the belts. Time as shown the pre-soaked cleaning paper cards are no good either but these cards can be used by letting the cards out and then putting de-natured alcohol on them. Some where along the way some people use a wet dollar bill as a cleaning card. To me, this is like cleaning your nose with a very dirty handkerchief. Just letting these paper cards run into the acceptor will not clean the entire belt length. You have to hold the card as the motor is running to make sure you cleanse the entire length of the belts. Then let it fly into the acceptor. Another enigma of too much cleaning is tightening of the belts. Lubrication and belt tension adjustment are crucial procedures. Never leave the pressure roller wet. It is not a good idea to leave a wet pressure roller against the head or leave the front input rubber roller wet. Always run a dry paper card into the acceptor so all excess alcohol is removed and the equipment is dry.

How about rubber drive cleaner to refurbish the belts? You can rejuvenate the belts somewhat when you do your routine lubrication and cleaning. You can use motor test button to run the acceptor and use a swab to apply the cleaner. Then use a dry card to dry the belts. The newer logic boards do not keep the motor running so I have made up a cable with four plugs. One plug for CBA-1, one plug for CBA/UCBAs, a third for OBAs and the fourth for a BA50. Regulated +12 vdc is used to drive the motor and a DPDT, center off switch can be hooked up for forward, reverse (+/- swap), and OFF. Besides using the voltage to run

the motor, I also use it to adjust the belt tensions. Adjusting the belts this way is the only way I can be sure I do it right.

A repair facility may not see those acceptors which are being taken care so my commentary is slanted based on the acceptors being repaired. If acceptors are given TLC it may be many years before the acceptor has to be repaired. Remember TLC means less wear and tear on belts, shafts, motors, and at the same time the acceptor does not suffer from lack of lubie stickation. TLC also means more bucks (\$) in the bill box. It all goes back to "If it's working, leave it alone", but, who defines what "working" really means. TLC is defined as cleaning belts, optics, lubricating per manual, cleaning or changing the pressure roller, and making adjustments including front belt tensions and checking motor to nylon gear adjustment. I find many CBA-2s where the front belts have tightened up so much and I have to re-adjust belt tension rollers. In some cases, I end up at the bottom of the belt adjustment and they are still too tight and I have to change the belts. As the belts tighten up and the lubrication is drying out, stickation becomes commonplace and this puts extra wear and tear on the acceptor. The rear belts are stretched and have to be replaced. Worst case history of a new acceptor in a dirty location was lubricated at least every 3 months by the vendors but only the parts that could be seen but none of the oil points behind the inlet or the lower section were done, In another case the acceptor was in outside and was hit with the hot summer sun). In 9 months, the acceptor had stickation. The acceptance rate, depending on the resting idle time, the bills were getting stuck in the acceptor because the slow speed at start up. Once the acceptor got up to speed, it could accept bills providing you put them in one after the other. The vendor cannot understand by he gets reports that in the morning the acceptor does not acceptance bills and bills get stuck. The person cannot understand why this happens since he cleans the belts, does lubrication once in a while (but remember he took a big

short cut by only doing 1/3 of the lube job) once in a while and it works fine when he checks it out.

Is your acceptor really "working" as it should be or does it have stickation, are parts worn, does it have bad belts already? Just because an acceptor accepts a lot of bills in a row does not mean the acceptor is working! Could you be in what I call "vendor denial" like this vendor? Sometimes you have to forget what some manuals tell you. Common sense tells you to oil the acceptor after it squeaks or it freezes up is wrong and is nonsense. The shafts, rollers, and nylons should be lubricated so the wear and tear is minimized. The oil used should be 3 in 1 Motor oil. A needlepoint oilier is the best tool to use to lubricate the acceptor. I call them Magic Wand Oiliers. Another common sense item is the motor will be working harder if belt tensions are too tight or if there are shaft and roller problems so the belt and motor failure rates increases. With extra current going through the brushes, the motor brush burn rate will increase and the added pressure on bearings will cause additional bearing wear too. The consequence of shaft/belt/motor difficulties could also affect the control unit module. You do not want this expenditure. Justification for preventive maintenance should be apparent to you. If you do not think so, keep reading.

You can read a manual and you may never see a schedule for preventive maintenance. Did you ever see "lubricate every \$ 20,000" or every 6 months. Common sense tells you no matter who made the equipment, a maintenance schedule of some kind should exist. The schedule will vary depending on the activity and the conditions in the equipment location. A machine in a nice clean bank or office will require less attention than a machine operation near a sandy beach or in a dirty factory. A machine that gets very little use has a limited "time factor" will require a schedule based on TIME. Without sealed bearings, the acceptor is like a car with an oil leak in the bottom of the oil pan and the oil dissipate even when the car is not running.

For any number of reasons, you may have to remove an acceptor and you will not have a cover plate that can be used to block the hole. There might be a plate that fits the machine, but in some cases, there is no plate. Before the problem comes up, you consider getting or making a plate to cover the hole left in the machine when the acceptor is removed. A better alternative is to have a spare acceptor.

If you repair your own equipment, you will have to decide how time and money will be allowed for the repair. A quick fix or full repair? Can you lubricate a CBA unit? While the CBA-1 does not have the logic module on the bottom, the procedure for a CBA follows the same procedure for the CBA-2/UCBA-2 acceptors. You will need a Magic Wand oilier or your own needlepoint oilier. The correct tool for changing dip switches, small screw driver to adjust speed adjust (if one exists), power supply or power cord so you can power the unit, a 12 vdc power supply with plugs for direct connect for the CBA-1 and CBA/UCBA-2 motors will help. Switch setting for the stand-alone Test mode 1,2,3,4 on, all others are off. Get the acceptor powered up and watch the stacker cycle. Check the acceptor status led, it should be off. Check acceptance, sound of motors, etc. If the bills are hung up in path, I check it with the mylar strip. First backwards and then I use it from the front. Junk, cuts, or nicks can be felt as the edge of the Mylar hits the cuts or nicks. Assuming it is ok and check the sound, speed and slowness of the belts. If belts are slow or not moving, perhaps the upper drive pulley is broken. When you cut a tie wrap, did a small piece, or other objects get into the inters of the acceptor? You should now have an idea if the problem beyond simple lubrication. You have to decide if your are going to bite the bullet at this time. This is where I have said try lubrication and cleaning a CBA that is working and not one that is dead or has other problems. Pull out the manual and look at the lubrication section. After you become lubrication pro [A Magic Wander] then you can handle other problems where

lubrication is only part of the total repair.

The status indicator will be normally "off" indicating the acceptor is ready to accept a bill. If there is a problem like no coins in mech, etc, and acceptor is told not to accept bills and status indicator will be lit. There is a partial test you can make on the CBA-2/UCBA-2 to tell if the acceptor is in trouble. Turn off power. Remove external cables leaving the power connected. Record where the switches are set. Put on 1 2 3 4 on, and 5 6 7 8 off. Re-power or reset the acceptor. If the acceptor fails to accept and stack the bills, the acceptor does have a problem. Some Coinco versions do not work in this test mode and they must be connected to power and the coin mech. The 1234 on test mode does not check the external logic interface part of the acceptor but if the acceptor does not work in the 1234 test mode, (Coincos aside) there is a CBA/UCBA acceptor or power problem. Assuming the power LED is lit, and a STATUS LED is steady on or blinks will indicate the problem exists with the acceptor. You can fix some of the problems in the field by checking the manual to see what the blinks indicate. The manual might refer to V1 or input sensor. You might just have a blockage of the input sensor or it might just be dirty.

When a bill is rejected, you have to watch the STATUS LED to find out why it was rejected. Just leave the bill there and count the blinks that tell you why the bill was rejected. Do not remove the bill from the acceptor until you have counted the blinks otherwise you might get a 1 1 1 1 1 and this is not the true V1 rejection code error.

Counting the error blinks does not always indicate why a problem occurred in the first place. Example; 4 blinks = V4 anticheat lever and you may find a bill stuck in the bill path. You can clear the bill and reset the acceptor and it works ok but what really happened? A bill should have been rejected the bill but the acceptor failed to eject the bill all the way. It might have dirty belts; it needs lubrication, tight belt tensions, bad logic module, a nick in the track/s that catches the

bill when the acceptor is operating in reverse (outward) direction etc. These are just a few of the reasons why the acceptor ending up with a 4 error (anticheat error code) but this was only the end result. A real V4 flipper problem could be the flipper is blocking the light path but you do not see why the flipper is in the wrong position. If you look around, you may see one of the belts has slipped off the pulley and the belt is blocking the anticheat lever from returning to the normal resting position or the shaft as slipped out of the hole. In the magic wand oiler notes, I talked about level 2 problems where you will have to get the acceptor repaired, or you reach a point where you change a cell assembly board, make adjustments, or change the logic module module, motors, drive pulleys, etc, yourself. The error code may bring you to a point where the problem is: this or that, so you will need; this or that, to find out which part is bad and actually repair the acceptor. Its easy for me because we have this, or that, in stock and I already know how to take the acceptor apart and can put it back together. As you read the notes you will see why doing the proper TLC before a problem occurs is so important. These notes will setup the background for doing level 2 work on the acceptor. You should know how to do level 1, clean and lube before going onto the next level.

Damage can be caused improper re-assembly E and C clips. These clips are made with a press. One side is smooth while the other side is sharp. You have to put the clip back with the smooth side toward the roller or bearing. You have to look at rollers to make sure damage has not occurred because the sharp edge of the clip was placed next to the roller. Let's gets ready to open the acceptor! Wait! Get the manual and read it first. Did you think I would let you off the hook without; "Read the Book!"

You need to know a few things in the manual. How to get the inlet off, remove the module, (those little screws in the back will not let you remove the module), find the adjustments locations such as speed adjust (if one exists), and how to remove the lower

cell assembly without breaking the lower track plastic clip. The manual also shows what has to be lubricated. I also lube the bottom of the bill box pusher plate to get rid of the squeak and the stacker nylon/metal slides. I hope you find those 2 small bearings on the front input shaft. These are two very important lubrication points.

Remove the pressure roller springs, cell assembly board, and LED board for V1. Clean the photo diode and LEDs. Check the pressure roller. Clean it with tape. Replace the pressure roller if it is bad. Replace pressure roller springs and the assemblies. Now, have a go at the acceptor with the oiler. Use the pictures in the manual. If you have the 12vdc and motor plug, you can plug in the drive motor and this will help you clean the belts with rubber drive cleaner. Re-assemble the acceptor, check/set belt tensions, and set the motor speed if the unit has old style logic module. I hope you now have a working acceptor.

The "L" shaped pressure plate in the bill box must have the small lip at the bottom of the bill box pointing to the back of the bill box. Sometimes the metal bracket just under the bottom of the bill box can slip out of the slot it belongs in. The shaft for the anticheat lever can also slip out of the hole where it belongs. This can mess up the anticheat alignment and the unit will not operate correctly.

Packing the acceptor for shipment: We have noted acceptors can have shipping damage due to poor packing. The most common problem is the acceptor transformer as hit the edge of the box hard enough to bend the top plate holding the transformer power supply and sometimes even sides the acceptor. If you use popcorn type packing, put the acceptor in a bag first. Besides getting all the popcorn out of the acceptor, damage to the acceptor can occur when it is started up. A hidden piece may show up down the road and you may have an acceptor that might fail again. When sending an acceptor for repair, or exchange, always indicate the problem that caused the

acceptor to be removed from service. Always count and record the number of blinks error codes when it is at rest and/or when the bill is rejected. In some cases, when the acceptor is checked on the bench, it has no problem! We use a different AC line voltage and bench test power supply so I have no power problems on the bench. You may have had a pinched wire/s under a mounting screw and the problem went away when you removed it from the machine or bracket.

Not using the juke box R92/93/94 or CD100 metal spacers between the CBA-2 and the mounting twists the acceptor frame out of shape when mounting the unit. You may now have poor or no acceptance or it may be ok for a while but as the oil dry up you have acceptance problems.

Intermittents may have existed, cells, LEDs may fail, or a stickation problem occurred. It is important to know which error code failure occurred and what was the reason you removed the acceptor from service. Do not assume the problem will show up on the bench. "It does not work," or, "it will not accept bills" is not enough information. What is the error code and why was it removed?

I know of many cases where failures are due to the mis-handling of the small 2-wire interface cable on 4900s, jukeboxes, and Nostalgic juke boxes. The CBA-2 is sent in for check, repair, or exchange but the problem/s still remain when the service person attempts to get the machine back on line. Swaps of computer control units may even taken place and the machine is still not back on line. Besides a bad cable, maybe the service person used the small side 2-wire connector but they have a new version module and the 2-wire plug goes in the bottom connector near the reset button and not the side connector.

Operator error or oversight could mean a large amount of loss time and money for the vendor and us. Some vendors run a 10% re-check of equipment that has just been repaired because it does not work yet the

equipment does work when it is re-tested. The total recheck rate is about 2 %. Out of the total 2 %, most of the equipment does check out ok on the bench. Much of this 2 % is operator errors like not setting switches correctly, leaving out the spacers on jukeboxes or wall boxes mounting frames or other problems like low voltage, bad cables, etc, or something else in the machines which keeps the unit from working. Yes, we do have real problems were a unit does not work, but not very often. If you have "tested ok" tickets then you find out why the unit had to be re-checked.

A history of one vendor showed the failure modes are mostly connector related maybe do to abuse. A loose connector bent pin, pinched wire, and a blown module that may have been caused by leaving the power on while working on or swapping the acceptor.

The status indicator will blink if a problem exists or when a bill is rejected. Record and report the number of blinks when the acceptor is removed for service or exchange. Many machines also have System error codes numbers. When you bring your car for service do you say: "It does not work", or just leave the car there with a presumed "fix it". I do not think so! I will bet you are very specific; at 50 mph, the front-end shakes or I hear scraping noise from the front wheels when I hit the brakes. It may cost you extra bucks when the error code and failure is not given when the acceptor or equipment is returned or exchanged. Do not call us and say "you did not fix the problem" when you did not list what the problem was. Short form comments do not mean much. Well, on what machine or system. The credit outputs have several different paths, configurations and interface kits. "The bill goes in so far and will not accept the bill." Well, how many blinks on the status LED when the bill was returned? "The bill accepted, and stacked, but no credits on a 448E2", etc, is more like it. Many units come in for service with no information at all. Here are some replies to questions about various problems; What was the error code or number of

blinks?

I did not look.

What was the error code or number of blinks when the bill was returned?

I did not look.

Did you check, or adjust speed?

No.

Was the "Use correct change" light lit? I did not look.

Did the stacker actually stack the bill?

I do not know.

Was the stacker in the home position?

I do not know. What was the line voltage?

I did not measure it.

Did you clean the connectors?

No.

The other side of the coin is many service people report the problem correctly all the time;

4900 single board with CBA-2, the bill goes in 3/4 of the way and status blinks 3 times when the bill was returned. Or:

The CBA-2 blinked 1 1 1 all the time. I cleaned the V1 LED and cell but this did not help. The replacement acceptor worked in the machine. Sometimes you can be miss-lead by reports and strange things can happen. This happens quite often with a CBA-2 used in an R92/93 jukebox or wall box. "It has poor acceptance, and just it about runs. We may have no acceptance at all and the voltage is ok." You remove the acceptor from the mounting frame and plug it in and the acceptor runs and accepts a bill (provided it is in good shape). What does taking it off a jukebox-mounting bracket have to do with acceptance? When the mounting is setup correctly, 2 metal spacer bars where used to match the CBA-2 to the mounting bracket. Without these 2 spacers, the CBA-2 becomes twisted out of shape and affects the CBA-2 enough so there is no, or poor acceptance. You will lube, adjust speed and then put it back in the frame without the spacers and it may not work. You need the spacer bars between the CBA-2 and the mounting frame. There are no ifs, ands, or buts! The strange part about these spacer bars is nobody ever took them off, knows where they are, and they are never found in the juke box! Spacers (2) are

Part # 3-09292-01.

Some CBA/UCBA have speed adjustments but the newer units (NV - switches on bottom) do not. Some units have adjustment hole and others do not. On older units, you may have to move module down and back to see the speed adjustment pot. Make sure you have the correct tool and pot. Push test/reset button and adjust speed pot till the status light stays on.

I have lectured about switches and you have to know where the switches must be for the acceptor to work in a given installation. Like knowing which acceptor you have, you will also have to know where the switches go. You must have a tool or probe which can reach down in and slide (or push down) the switch levers. Some acceptors have a black cover that blocks the switch a little bit so a tool (probe) must have a small bend in it so you can reach beyond the cover. The end of the tool will have to be small enough to allow pushing the switch levers down, or slide them over the ON or OFF positions.

Never assume if you send an acceptor in for repair or exchange, the switch settings may not be where you need them. Always record and keep the switch settings for each machine, game, or bill changer.

1. A common setting is all switches off. The machine talks to the acceptor and tells it what to do. Accept \$1, \$5. Hold, stack, etc.
1a 5900 new vending machine
(If program is Version 4 up) requires switch #2 be turned, all others are off.
2. Wall boxes for jukes, or TEST mode
1 2 3 4 on, with the rest, 5 6 7 8 off.
3. Late CD100-B upwards, Eagles, 4900 snack, SBC changer: use Rowe Link
1 3 4 on, 2 5 6 7 8 off.
> NOTE: Warning! For 4900 single board, CD100-C external 2 wire plug: On some CBA/UCBA-2s Switches inside, the plug is on the edge of the board, but on the upside down NV board with plastic shield and switches on the bottom of the logic board, the plug you want use located on the bottom of the board near the switches and not the

side connector.

5. Special Game and OEM modes require special switch settings. Make sure the switch settings are recorded so you know what they are to be set.

Since the mode (or switch settings) made be related to a given problem, where the acceptor is used should be reported when the acceptor is returned or exchanged. The 1234 test modes does not check the module for external signals so there is part of the logic which is used in external mode operation which is not checked in the 1 2 3 4 test mode. Please note that some Coinco versions do not work with stand alone test with 1 2 3 4 on. They must be connected to coin mech to operate correctly.

Warning: I have seen new version module switches where the little ON and OFF was printed in reversed position or you miss the little arrows pointing to the other side of the switch.

Again - Please note on the 4900, or CD-100-C jukebox, new Nostalgic jukebox, the little 2-wire/plug goes on side wide when switches are inside the acceptor (old version), and on the bottom when the switches are on the bottom of the new version logic module (NV).

//// Power supply transformer \\\

The power supply may appear to be just a transformer but there is a full wave bridge and a filter cap located with the transformer case. In the case of the COINCO CBA-2 supply there is addition electronics located with the transformer case for interface circuits. If you decide to swap a CBA-2/UCBA transformers, a voltage test should be made first. If the power supply is bad, you might BLOW the second CBA-2 or UBA. Always check the voltage and AC ripple voltage before attaching a power supply transformer to a CBA-2/UCBA-2. To do a stand alone voltage test a resistor load of 25 ohms at 15 watts can be made from three (3) 75 ohm, 5 watt resistors.

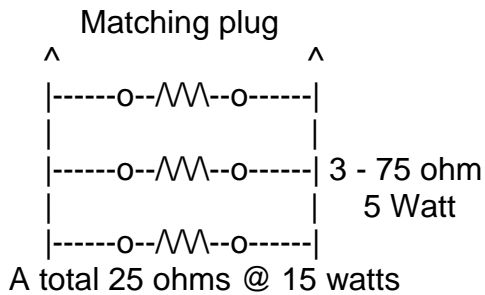

A voltage test should be a routine test for CBA-2/UCBAs. You need a meter which will check DC, AC ripple/noise and it should have small probes. The small probes are needed so you can get to the power connection (mostly Red/Black) wires in the power plug of the CBA-2/UCBA-2s while its still plugged into the logic module. The voltage should never be below 12 vdc with the acceptor under load (with belt motor running), and never more then .600 mvac (.6v) AC ripple. At rest, the ripple is normally < 100 mv. The AC ripple MUST be read under load of the motor running or using the resistor load shown above.

Note: Some meters will read the DC component when the AC scale is used and they cannot be used to read the AC ripple on a DC voltage. When OEM or CD wall box power supplies are used, the same test should be made. With connectors and wire voltage drops the voltage at the CBA-2 might be less then 12 vdc under load. Maybe around the 11.6 vdc mark. It may appear the acceptor is working at this voltage, but with a little aging, the acceptance rate will quickly drop off to zip. In the mean, while you may loose many bucks and you may presume the box is not doing as well as you think it should. If the wall box does have less then 12vdc, the wall box power supply may require a mod. Change the 240 ohm voltage set resistor to 220 ohms. This might bring you up to about 12.7 vdc at the power supply. This is not an official ROWE mod. With the several already done, we have not had any problems. No mod was done without taking voltage readings before and after the mod. This is not a shotgun mod and is done based on the voltage readings taken.

Remember if the AC line voltage is low, the power supply voltage will be low too. I have gotten reports of poor acceptance and the line voltage in various locations were reported to be low: 88, 95, 102 VAC. I have recorded AC line voltages swings of 95 to 135 voltages in location located 2 miles from factory area in Framingham Mass. Others have reported massive AC line voltages swings because of overloading a circuit, loose or bad wiring, or major line voltage problems in a building or just to many thing one circuit. The voltage could swing depending on time of day, or things like heating, air conditioners or even vending machine compressor demands. You may find the AC line voltage ok, but other equipment on the same line may not be operational (on) at the time you check it. As one example, when the compressor in the vending machine, or other machines is running, the voltage may drop low enough to effect the bill acceptor and sometimes it might effect the main control computer. In other notes, I cover an AC problem and poor acceptance with CBAs that went on for long time. It all came down to the tests were done during the daytime, but the low AC line voltage drop appeared only at night when the Smoke Eaters came on. Thank god for those new digital meters like the Fluke 12 have a Hold MAX-MIN readings option.

A word about the head assembly and the tracks. Assuming the tracks are ok, you are still going to run into an acceptor where a mag signal has fallen off and the acceptance rate is down. AT some point in time wear and tear on the magnetic head means it will have to be replaced. The head is aligned at the factory so it comes only as an upper track assembly. You will have to replace the entire upper tack head assembly if the head is bad. I make use a special Bruno test I designed for the magnetic head assemblies. Anything can effect acceptance; speed, belts, lubrication, pressure roller, springs, tracks, etc, so it will be hard for you to tell if the poor acceptance problem is the head assembly. There is no pressure roller solenoid in the CBA/UCBA acceptors so

times cable/connectors were checked but loose pins and broken wires have been found and fixed. I have seen people attempt to check a cable with an ohmmeter set beep and diode position and still have the cable plugged into the equipment. Paths through the acceptor and control units show or beep so the user thinks the cable is ok, but in fact, is not ok! use a mating connectors plugged into both ends of the cable and measure the from these mating connectors. Other tests, like using valid voltages, can be used to confirm correct operation.

===== CBA-1 Info=====

For those who have CBA-1 acceptors here is special information. The speed and mag control can be found on or in the CBA control boxes. A few comments about the nostratic juke and OEM/AP -03, 05, 07 control units. The speed control (a small pot) is located on the lower board. There are 3 pots on the top board and the one on the lower left "R45" is the mag gain. It is located behind a cap that gets in the way of the adjustment screwdriver tool. Generally, the mag adjustment of the mag gain is very tight and in some cases you will have to split the range between a soft older bills and a new harder bills. The range might be around 10-11 for old bills and 11-12 for new bills. The adjustment would therefore end up at 11 o'clock. Rowe has changed value of C8 to 2.2 mfd to improve acceptance range. In any cases, a 2.2 has been soldered to the top of the existing C-8 cap.

===== CBA Motor Systems =====

A DC varying on the motor controls it's speed. Reversing the voltage + - will reverse the motor direction.

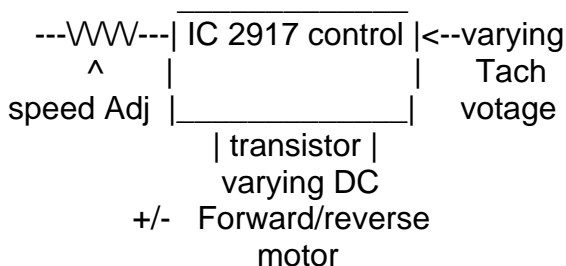

The speed adjust resistor sets a reference

that is compared to the Tack signal coming from the motor. Normally if controller does not see the motor's tach signal, the motor will at very high speed. No tach signal could be a bad connection of either one or both of tach wires that bring the signal back to the controller. It could also be a bad tach signal within the motor or a controller with a problem like a shorted motor transistor or bad 2917 IC.

In a case the motor running at hi-speed, the tach wire was open at the cable plugged into the acceptor connector. An ohmmeter test was made but cable was left connected on both ends when the test was made. The broken (open) connection was not found because leaving the cable connectors plugged into the equipment and he used the signal tone and diode position on the meter. This gives misleading test results. It is a false positive. The best way to check a cable is to plug mating connectors into the cables connectors and measure the resistance on the mating connectors.

A shorted cable or bad acceptor can reach back into the control unit and blow many ICs. One thing you can do is to open the unit and look for the 2003 IC on the top board. Serious damage may shows up on the top of 2003. It maybe burnt or may even have a hole in it. This is generally a result of a short of 24 vdc to the 5 vdc in the acceptor, cables, solenoid, diode, etc. If you get another control unit and plug it into the system, <poof> goes the second board. Always take the cover off and look at the 2003 before replaced it with another unit. Never plug a bad unit into working machine. Look first!

Do not mix up stacker and motor plugs on the CBA-1 interface assembly.

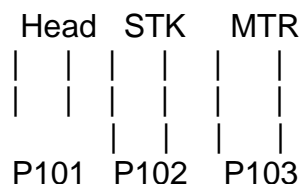

The upper drive shaft parts on a CBA-1

differs from the CBA-2. There is pulley on each side and the pulley is held to the shaft with a pin. You will a 3/32" punch to get the pins out and you can squeeze the pins back into place. Vise grips or channel locks work ok till you squeeze you fingers in the tool. Be careful! Like any acceptor which is not taken care of, jams and strain may occur and when this occurs, the pulleys may crack at the pin area. The belt/swill then slip or mot move at all.

Rowe does have module updates which are referred to the new version which are the upside down board with the plastic water shield over it. Today they are for new (not so new now) \$5. You have to know if it is and old style with switches inside or new version with switches on the bottom.

Today there are new modules that update to the new \$5 bill. The kits contained a new cell assembly and hardware needed to make the conversion replacement. Once you get to a point where you are doing the full cleaning and lubrication, you know then how to get into the acceptor and change the cell assemblies. The next logical step is to replace a bad module. But.... you could have problems. Most conversions work ok if you do not have other problems. The magnetic head must in good condition but there could be a problem with the cell in the magnetic head assembly. The new lower LED - cell assembly board and the new module may not work with the cell in the original magnetic head assembly. You might have to install a new head assembly or swap/find an old module to work with an older head assembly and then try the new module in another acceptor.

If vendors have not reconciled doing lubrication for an acceptor like an OBA, which simple to accomplish; then how can you handle a CBA/UCBA where they have to take things apart to clean and lubricate it? There are several factors to consider. The person doing the work is the key. I love the drop, drop, drop, of the Magic Wand Oilier because I know it works! Without it, the acceptor will not work correctly, but if it

does, it will not be for long. The person must have the desire to make it work and needs to learn what has to be done in order to make it work. The person has to be in a safe place, (situation) and must to be able to get outside help when the problems extend outside the normal cleaning and lubrication. This might be getting the unit repaired or have the full backing to be able to get parts like a motor, cell assembly or replacement module, spare unit, etc. Again, the person must be in a safe place, without stress, so the learning process can continue. Cleaning and lubrication is only the beginning and other difficulties will exist. If a person cannot say, I am stuck, or I need help, then forget it! If an imposed time stress exists, this might take away from the person's ability to learn, handle procedures, or the stress might impair the mental learning or do process. It really depends on the persons work style (order of things) and the extent of the lack of preventive maintenance period. Level one, cleaning and lubrication will have level 2 conflicts like defective belts, pulleys, magnetic assembly, damaged upper and lower tracks, or a bad logic module, etc. The only way to learn how to handle level 1 is to work on an acceptor which is still working and where level 2 problems do not exist. In the long term, level 1 work can be money in the bank for you! The time to start was yesterday! Has an acceptor wears, items like belts, magnetic head, etc, will need replacement and there will be other part failures or damaged.

In the last three months of 1993, 25 out of 106 CBA-2 (serial numbers 409xxx to 694xxx had bad magnetic heads. The percentage of bad units is actually higher since 'some' of 106 were sent to factory. Lets presume it was 24 % and ~+ 30 % in early 94. At the start of 1994 one vendor had five CBA-2s he wanted serviced. One was badly salted and the other four had bad magnetic heads and the acceptors had not been given any preventive maintenance. A simple clean and lube would not get these five acceptors back on line. From what I seen the chances of serious failures, like bad magnetic heads, bad motors, belts, etc,

is directly related to the lack of preventive maintenance. Look at the trouble section of the manual and note the procedures for each number of blinks on both standby and when a bill is rejected. These are levels of repair, or maintenance, which may be needed to done if the acceptor is in a level 2-failure mode.

I cannot leave this section of notes without talking about salting of acceptors. As far as I know, the only thing salting a CBA/UCBA does is to damage the equipment and it does not jackpot. The damage can include the metal shafts and parts and it can damage the electronic parts like logic module and also the Magnetic head electronics too. Once the electronic parts shorted or are eaten away by the salt, there is not much which can be done except replacing the assemblies. Other items have to be cleaned or replaced. One example is the magnetic head pressure roller. You have to remove the springs and check it. The salt may have reached the pressure roller shaft and the roller is, or in time will be, frozen and it no longer rolls freely. You will have to replace it. The shaft holding the roller assembly in place may damaged so it may have to be cleaned or replaced. The flat metal spring holding the pressure roller assembly shaft and lower front shaft may be weakened by corrosion and may have to be replaced.

The CBA-2/UCBA-2s have 8 switches must be set with the right combinations of ON and OFF for any given application. I have notes for some of the switch settings but you better keep your own notes and always record the switch settings if you remove an acceptor from a unit so you can restore, or check, these switch settings for any given unit you work on. Lets say you work on an acceptor from a single board 4900. The switch setting is 1 3 4 on and you decide to set the switches for a standalone test. The switch settings for stand-alone is 1 2 3 4 on. When the acceptor is put back into the 4900, the switches have to be set with 1 3 4 on. Remember to do a reset or power on-off after setting switches. Every application has

a given switch setting. If you get an exchange unit or swap an acceptor, chances are you you will have to set these switch to the right combination or it will not work correctly. A word to the wise, write down the switch settings.

For those who opened their mind up to new ideas, procedures, look and count error status blinks, etc, you got the message! If your magic wand oiler is empty, welcome to the "No More Stickation Club" and maybe "I Read The Manual Club"! I hope these notes helped you get your full membership in these very exclusive clubs. There are many people who make a living in this business and many do not know as much as you do now. These notes can be your Magic Wand if you choose to put in some "think time", and perhaps, modify your order of things based on the information supplied.

May the Manual be with you!

CBA, UCBA-2, and C/UCBA-4 Acceptors Part 2 - Level 2 Repairs and more!

This document covers a deeper level of repairing CBA/UBA acceptors. I presume you have already read my CBA/UCBA (Level 1), and The Magic Wand Oilier docs. These notes are basic and the work is common sense based. Many CBA problems are a result of no preventive maintenance. If you are a vendor who has decided normal maintenance is a no-no and level one cleaning and lubrication has not be done, more repairs and parts replacement will be needed. By reading this abstract you can increase your look-ie and do-ie knowledge. The depth of the knowledge gained will depend on your frame of reference and order of things. Some of the information to be given is common to both the CBA and CBA-2/UCBA-2s. The majority of the comments will be for the CBA/UCBA-2s (UBA).

The stress of working with a CBA/UCBA-2s can be handled best by just handling the problem/s at hand and overlooking stress factors. This means having a safe place to work and a release from time factors. Use a spare unit in the machine and work on the bad unit in the shop or even the kitchen table. If your preferred work style is the panic mode and time pressure, the above does not apply to you. One cannot learn how to do something new unless one is attempts to go through the process of actually doing a procedure. Fear of failure is normal, yet very human. Being at risk cannot be pushed aside until one masters the procedure/s. Stay where you are, or increase what you can do-ie! It's up to you! You can say to me; "It's easy for you because but you do it every day." Thats true, but where did I start? More important where, and when, do you start? You can start by taking time to note error status displays and count the blinks. Write down why you removed a given piece of equipment, and then keep going deeper into the problem. I just got a CBA-2, in pieces, (someone took it apart), and carefully put the parts into plastic bag. You might

consider this a failure, but my position is this person as taken a major step in learning process and well on the way to becoming a full member of the CBAer club. The person now has a deeper insight of what is in a CBA-2 and where things are because of this hand on experience. Can you take the stacker assembly out of a CBA-2 like this person did?

Since the CBA-UCBA work will be mainly mechanical and there is not much the written word can do to help you. You have to dig in and do it. 'Read the manual' other wise you can damage the acceptor when attempting to work on it. You can screw up when removing the module; break the cell assembly board, or the lower track clip that holds the cell assembly in place. Read the manual and get what ever you can out of it! Level 1 notes covered AC line, power supply problems and other problems not in the acceptor. Make sure the AC line voltages and/or power supply voltages are within normal operating ranges. All to often, poor or no acceptance is due to voltage or cable problems and not the acceptor. Any time the voltage goes below 12 vdc under load at logic module (normally the red and black) wires problems will occur. You will need small needlepoint type probes, or special leads to measure the voltage. Leaving a Fluke 12 or other meter which has max-min hold feature may be the only way to tell if a voltage problem existed. Remember the smoke eater problem where poor and no acceptance was caused from low line voltage. This never showed up during the day when the tests were being made. Also remember that juke wall boxes use the 12 vdc supply and this voltage may be less then 12 vdc leaving the supply and it may be even less at the acceptor. Any voltage less then 12 vdc is a borderline situation.

Beating a 'dead' horse to death; You have to find and fix voltage problems! The acceptor may be mounted with special hardware so be careful. The CD jukebox, or wall box units, have 2 long metal spacer bars (3-09292-01) which keep the acceptor from twisting out of shape when the screws are

tightened. The CBA-2 frame gets damaged because the metal spacers are not put back in place. The effect of not using the spacers could be no, or poor acceptance. The acceptor may, or may not, accept bills when its new or just oiled, but the acceptance may fall off quickly with time, wear, and tear.

The new version module does not a speed adjustment. When speed adjustment has to be made, the speed adjustment is made before the acceptor is mounted on the frame. Older units may, or may not, have the hole in the frame so that speed adjustment can be made. If there is no speed adjust hole, the module has to be manoeuvred back and down a little bit to make the adjustment. In order to remove the module from the frame or move the module down to make a speed adjustment on the older, read the manual. Remove the inlet screw and remove the inlet. Pull out all the connector plugs/cables going into the module. Now you can slide the module out of the frame.

You should take some time to study the acceptor to see what goes where before starting to take it apart. There are some tight nut places and you should have two thin wrenches. One 5/16" for the lower belt roller shaft pins on the bottom for the acceptor. A 3/8" wrench is for the two pin shafts used on the inside large black pulleys. You may have to buy thin wrenches or grind some down, or use alternate thin long nose pliers. The shaft pins for the big black rollers fit into holes in the head block assembly. Once the module is off, the lower parts of the acceptor are exposed. You have to get this far just to clean and lubricate the unit so if you are a Magic Wander; you have gotten this far many times. You can now inspect and change cell board assembly, pressure roller, etc.

Module repair may be as simple as replacing a connector, fixing an intermittent connection, relay, transistor, or voltage regulator. Sometimes replacing the entire module is required. There are three basic CBA-2/UCBA-2 new version (NV) modules. The new version has a full plastic shield

over the module and switches are on the bottom.

One word about the shrink tubing used to protect the connector extension boards when converting from the old version to new version. Because the interconnect board connector pins on the boards are sharp and pointed, when shrinking the tubing, the points can come through the tubing and may short to the metal frame of the acceptor. You may want to file down the points and take extreme care not to heat the shrink tubing so far down that the points come through the protective tubing. A problem can occur with the wires used with a wire version of the long lower cell assembly. The small wires now are passed up near the bill box. If a wire/s get caught by the bill box, the wires may get frayed, pinched or even cut by the bill box. V2, V3, V4 LED/CELL problems may be located on this board, wiring, or the wires are cut/pinched by bill box. The latest version of the cell assembly uses a flat ribbon cable and at one time, the cable was folded over to the side of the acceptor. Over time, a better routing of the flat ribbon cable was to go across the bottom of the logic module with a 45-degree fold to get to plug into the connector. A cable clamp on the module is used to hold it in place.

>>What about bad logic C/UBA-2 module boards? <<

Can you repair an acceptor? That's not for me to say. I have repaired boards with parts taken from old modules left after updates were made. Connectors where sometimes replaced and/or resoldered. I have replaced the motor drive TIP115 transistor. Take note that the TIP115 transistor on the control board is insulated from the metal frame. If you remove the transistor, and/or the voltage regulator mounting hardware, make sure all the hardware is replaced the same way it came off. The screw is insulated from the metal. Do not lose any of the parts. I have also replaced the 7805 regulator. Again, do not loose any of the parts.

Removing the stacker should become commonplace, either to fix the stacker

assembly, to tighten loose stacker motor screws, or to get it out of the way so you can do other work. You will have to cut the tie wrap and pull out the stacker plug. Open or takeoff the bill box. Remove the two screws holding the stacker. Some stackers have a wire, which comes out the right side that feeds the small "counter" plug. I normally cut this wire when removing the stacker. I respice it when I am done. When removing the stacker assembly, twist the left belt so the belt will clear the stacker micro switch area; start to slide the assembly down and out a little bit. Normally the the bottom of stacker pusher plate catches the magnetic head assembly cable so you have to move the cable out of the way so the stacker can be removed. Always make sure the head cable is plugged into the head assembly other wise you could end up with no acceptance. Check the screws holding the stacker motor in place. Make sure they are tight. You have to remove the pusher plate to get at the micro switch or motor screws. Never push the stacker arm backwards because this bends the micro switch actuator arm as the cam moves. Mark the nylon slides so you can replace it the way it came apart. There is a small pin in the upper and lower nylon slides and these pins must be replaced they came out. When you install the stacker assembly, make sure the magnetic head cable is behind the pusher plate.

The upper top plate may be damaged and have to be replaced or removed when you have to replace to upper drive shaft pulley assembly. Take out the stacker screws. Cut the tie wraps holding the transformer wires in place. You will need slack on these wires. Now remove transformer if you are going to replace the top plate. Remove the two screws holding the top plate in place. Be careful not to loose the small rollers near the top plate. These rollers can slide off the shaft pins. You can slide the top plate off. Reverse the process to put the plate back on. Be advised there are two types of top plates, the normal plate, and the plate that is used for the locking bill box.

When removing the front shaft flat rollers

above the upper track, do not lose the small end spacers, or rollers. When you remove this shaft, there is nothing holding the rollers and spacers on the shaft so they can slide off the shaft. This shaft is small and the coating takes a beating so you have to replace it more often then the other shafts. The Magnetic head upper track assembly may have to be replaced. You may not have a magnetic head test setup for checking the condition of the magnetic head so it will be a matter of trying a new one to see if it corrects the bad or poor acceptance problem. I see many older CBA-2s that fail the Magnetic head test. If you rebuild an acceptor, the magnetic head might be on the verge of poor acceptance and you may find the acceptor is accepting bills ok when tested but in a very short time, you may get poor acceptance when the magnetic head starts failing.

Sometimes track damage may be the problem and this damage can occur when someone does not have a Mylar or plastic strip to push the stuck item from the acceptor. Some one may have used a sharp object to remove something stuck in the acceptor and the tracks were damaged.

Your mag problems could be related belts, drive motor, pressure roller with metal particles, damaged tracks, and/or the magnetic head assembly itself. To change the magnetic head assembly, first remove the stacker assembly. You will want to hold the belts in place so put tie wraps around the belts just above the two small rear rollers. The idea is to hold the belts in place at the rollers while you do the rest of the work. Remove the connector going into the headboard and the screw holding the V1 photocell in place. Remove the screws (use small thin wrench to hold pins) holding the large black pulley pin shafts since these shafts do go into holes located in the head assembly. The flat metal bracket on the head assembly locks into the side of the CBA/UCBAs. If someone has forced something in to the acceptor, this bracket may be bend out of shape. Be careful and do not bend the bracket. A bent bracket may

increase the size of the opening and move the belts apart from each other and/or bent the holding spring for the shaft and rollers on the lower track. The bill may slip and not be pulled into the acceptor. Generally, when a head assembly has to be replaced you find the shaft pins for the two large black rollers are worn. Since you have it apart, replace the two pin shafts if they are worn. Keep two (2) B00319-24 pins and 1 B00318-30 shafts on hand. New CBA/UCBA-2 head assembly part number is 6-50707-04.

From the Basics 101 notes you already know ohms laws and that a LED, [Light emitting diode], are much like zeners at approximately 1.1 to 1.2 vdc. Some LEDs can also be at 1.9 – 2.0 volts. The Power and Status LEDs emit light you can see but other LEDs emit infrared light so you cannot see visual light emitted from these LEDs.

To test the LEDs, measure the voltage across LED and R. In an example case given below, measure the supply voltage [Es] from the hot side of the resistor and gnd. Measure 1.2 vdc across the LED and 3.8 vdc across the resistor. Since the current is important, do not assume the orange/orange/brown of the resistor is the value. Measure the resistor (R) and in this case it does measure 330 ohms.

$$R=330 \text{ ohms}$$

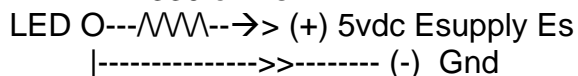

Ohms law for current

$$I_r = E_r / R$$

$$I_r = 3.8 / 330 = .01151 \text{ amps or } 11.51 \text{ ma.}$$

If the 330-ohm resistor had a real resistance of 552 ohms, the current through the LED would only be;

$$I = 3.8 / 552 = 06.88 \text{ ma,}$$

If the Es was down to +4.0 vdc, the voltage across the resistor would only be 2.8 vdc or :

$$I = 2.8 / 330 = 08.48 \text{ ma.}$$

If something is bad, a valid test will point where the problem is. This might be the +5 volts is low, the led is shorted or has a

solder short across cell, there is a cold solder joint, wire or copper open, etc. When using a test like this one, Bruno's law applies; If a part checks out 'not bad', that does not mean it is a 'good part'. The light output may not be enough or it may drop off with temperature and/or time. Blockage of light, dirt, mis-alignment, the photocell and electronics reading the light source, adjustments, etc, are just some of the quandaries that will have to be addressed.

There is another consideration to be made when working with photocells and photo diodes. Like an OBA with the top cover open, light from a light fixture or sun light can affect the cells. Voltage readings can be affected with various results. You may make the wrong adjustments, have error blinks indicating cell problems or have poor, or no, bill acceptance. I see these external light problems on the bench and many times when working on an acceptor in an machine with the door open.

Keep in mind; even if the voltage and current figures are ok, the light emitted from and LED may not be correct. It comes down to replacing the LED or photocells or the assembly. Maybe wiring, connector, or logic module. Some models do have adjustment so check the manual.

Replacement of opto devices require the device be reinstalled the same way it was removed. This assumes no one else screwed it up. A little flat spot on the LED might be the key or direction that the LED is mounted. Some photocells have a small metal tap as a key. The LED may have a flat area that serves as a key. Many of the fix-it people fail at a procedure such as changing a LED. Perhaps lack of do-ie knowledge, not having the correct soldering iron, tools, doing the work in wrong place or at the wrong time, stress, etc.

The vending business has been getting away from this type of work and has started thinking in terms of throwaway assemblies. The state of the art is becoming; "Send the unit in for repair or exchange."When an

acceptor starts slowing down because of wear and tear, and/or lack of lubie, increasing the speed adjustment will apply more voltage to the motor. When this occurs, additional current will be used and extra power will be used to override the already failing mechanical parts. This increases electrical damage to motor brushes and motor transistors. Increased stress also causes damage to motor gears, bearings, shafts, belts, etc. The new version modules do not speed adjustment and some of you may feel this is better since its one less thing to worry about. This is true, but if abused, you are permitting premature destruction of the acceptor. There is a trade offs so mediate over "no speed adjust" feature because this feature does not mean you can go without doing the required preventive maintenance cleaning and lubrication of the acceptor.

Read the book! Error codes can be an important pointer to what area or part is giving a problem. Some error codes fall under a blanket problem of speed or transport. Let's take one example where you have to go beyond the manual's information and go directly to visual inspection of a part. The input rollers and shaft has two blue bearings, two white rollers on both ends and the rubber roller in the center. The rubber roller maybe dirty or worn. You may find the rubber roller has broken away from the shaft and the rubber roller is freewheeling on the shaft. The belts may, or may not, pull the bill into the acceptor so you have to apply pressure on the roller to see if it's slipping, If it slipping, the shaft/rollers will have to be replaced. When the rubber roller breaks away from the shaft, sometimes the lack of bill pull makes you think there maybe some debris stuck in the acceptor. If you take off the inlet cover, you may find the rubber roller is no longer connected to the shaft. Make sure the rubber is still attached to the shaft of the input roller assembly. The flat metal spring holding the lower shaft may be damaged or bent out of shape so it no longer has enough tension to hold the shaft in place, and/or, the lower center rubber roller does not have enough tension. This

spring damage is another result of jamming some object into the inlet in an attempt to get debris out of the acceptor.

If you replace the little input roller assembly with the two blue bearings, install the blue bearings into the two holes provided for these bearings. If the shaft assembly bearings are not in the holes you can tighten down the two screws holding the metal plate in place then the shaft assembly will be very tight and put drag on the system. The acceptor may work but the motor may be straining to override the tightness of the bearings. Make sure the bearings are lubricated!

Looking at the Magnetic head assembly you will see the two large black rollers and the shaft pins that go through a hole in the lower track. The pins go into the lower track and rest flat against the metal side. You may find it/they did not go through the hole and are caught on the lower track. The shaft pin may be cooked out of alignment. This will effect belt alignment and tension. The Stacker pusher plate assemblies can be twisted and cause problems. The CBA (1) plate can be twisted so it sits with a sideways bend, The other CBA/UCBAs the vertical alignment may be off or the top slide section may be bend of of shape. With all CBA's, the plate can stick in the bill box and rather then removing the bill box first, brute force is used to open the bill box. This force distorts the plate assembly. While you may not have caused the damage, you will have to keep an eye open for this type of damage. Sometimes you can reform the assembly. Sometimes replacement will be required. Excessive damage may have been caused to the sliding hardware and the plate is loose (sloppy) so the hardware may need replacement. Plates can be the cause for poor stacking or V4 - anticheat errors if bill gets stuck. A bent top plate which can get bent in handling or shipping and it can stop the stacker pusher plate from moving freely.

In early 1996 a few defective CBA/UCBA bill boxes got out into the field. The metal tabs on the bill box which hold the bills in place

are about 1/16" to large on one side of the bill box. If the stacker hangs up, look at the tabs on the bill box and compare the 2 right side tabs to the 2 left side tabs. If you have one of the defective bill boxes, you will see the difference. To fix the problem you can file or grind down the excess metal. or replace the bill box.

The pusher plates have had many changes. Some CBA (1) plates had rubber runners at one time. These may create a problem when the bill is caught on rubber runners that have started wear out. You may need a newer push plate if you cannot repair the rubber sections. Another stacking problem might be the bill box is bent out of shape. This bend be in a form of a twist, or a bend at the top the bill box. Inspect the bill box for damage. The plate within the bill box has a small lip (bottom) which must be ride along the bottom of the bill box and it has to point toward the back of the bill box. Some vendors let the bills pile up in the bill box till there is no more room. The stacker motor has to fight hard to stack the bill. The added wear and tear is enough to wipe out the stacker motor and even the control module. This could be quite a large repair bill. There have been several reports of problems of CBA/UCBAs in shut down because the bill box got filled. Other reports of shut down may be related to filled bill boxes but operators have not checked the status blinks and just reset the CBA without knowing why the CBA goes into shut down.

By now you should know most the problems start because of a lack of preventive lubrication and cleaning which leads to other problems like stickation and other hard failures. You have to accept a magnetic head may start to fail or has reached the fail mode. Be prepared to replace the magnetic head assembly. Replacement of broken drive pulleys in CBAs, CBS-2s, and UBA-2s is another example of not taking care of your acceptors. Even if you could change them yourself, chances are you do not have any in the toolbox or on the parts shelf. Breaking the CBA down to the nitty gritty, we have several parts like modules, head assembly,

stacker, power supply, cell assembly, stacker assembly, shafts, pressure roller, and belts, etc. Having main parts on hand allows you to replace parts when they become defective or worn. The expertise to find the problem may be as simple as replacing it with a good one. At some point, the acceptance will fall off when the head assembly is worn or bad. So replace it. As always, changing just one part of a system may not fix the unit. Bad belts, a lower track with nicks, or lack of lubie may also be related to the poor acceptance of the acceptor. You may have to fix more one then just one part of the system in order to get it back on line. In the magnetic head example, you can do all the lubrication, cleaning, etc but if the head is worn, the acceptor will still have poor acceptance. The more work you do on the CBA/UCBAs, the easier it will become provided you remove the stress and have the parts. Generally having a spare unit (that works) is the best way to remove stress.

Rowe has changed the lower cell assembly a few times and there have been a few V2 and V3 problems over the last few years. The original logic modules had adjustments but the new version modules do have no adjustments. The error status blinks will indicate a V2, V3 or V4 problem. Bad lead connections on LED and V2 cell have been noted on cell assemblies. De-solder, scrape leads and re-solder the leads. The coated cell assembly may need to be re-soldered and sometimes the LED or cell has to be replaced. In most cases, replacing the lower cell assembly assembly fixes the problem. When making cell voltage readings remember external light will screw up your voltage readings. VR is a term now used for the V2 LED-Cell combination on the lower cell assembly. VR = The voltage Reflected from LED to the back side of the bill and back down to the photo cell. This voltage has two important voltage states. One is with nothing in the bill acceptor and no external light hitting the lower cell assembly board. The state is when a white card is placed in the acceptor. Both states are important. Generally if the resting state

(nothing in the acceptor) is over 4 volts, the reflected light off the white card (or bill) will not go down far enough and the result is bill rejection with a VR (V2) problem. If the resting VR voltage is too low you may get a condition where \$5 is accepted ok but you get VReflective/V2 (2 blinks) failures when attempting to accept \$1 bills. If the LED and cells are dirty there will be a problem. Debris could also be in the acceptor. I have seen all types of problems, alla dirty LED and cells, bits of paper, clumps of dirt, parts of bills, coins, leaves, gum wrappers, gum, etc, blocking or hampering the light path between the LEDs and cells. Sometimes cleaning the dirt on the LED and cell may restore the acceptance but there are times when the basic voltage are shifted one way or another so cleaning may only be a short term fix. It is a good idea to keep a lower cell assembly on hand. Keep in mind an old, or a new part, may be defective. Solder connections may be bad, crimp connections may not be tight, or the LED may be out of alignment. I have seen some LEDs which were not be hitting the V3 (the photocell in the magnetic head assembly) correctly and they had to be pushed into the proper position.

Cell problems will vary so look at the blinking status indicator. In one example just described above, a CBA would accept most \$5 bills and almost none of the \$1 bills. The status error reports a VR (V2) problem when the bills were rejected. How would you handle this problem? The fix was to replace the lower assembly board since both the LED and photocell are on the assembly. In case you a meter person, you would have found the VR voltage (at rest) was too low. Meter or not, you still need a lower cell board assembly or the specific cell! In most cases I change the lower cell assembly because the new version is coated and/or soldered the leads removes the protective coating between the cell and LED leads.

In 1996 Rowe having noted the amount of LED and cell problem over a long term starting doing better checks if the LED and Cells. Having found some of the problem

were the wires on the lower cell assembly Rowe introduced a new assembly with a flat ribbon cable and a new clamp too in February 1997. The new assembly part # is 45073506 and the clamp is 71200001. There have been a few different versions. Now a days the flat ribbon cable is run down to the bottom of the module and a 45-degree fold is made so it can be plugged into the connector. A clamp is used to hold the cable against the module, You may end up getting and replacing a new lower cell assembly to resolve V!, V2, V3, and V4 problems.

There are some conditions when a status error which points to a specific area or parts but the cause may be some where else in the acceptor. You may get mag error but this could be to electrical noise from the motor. You may get a V2 error that is related to something else other then the lower cell assembly or module. Cross-referencing an error to the real cause may be hard to find. It may not happen to often but remember a given report may not be directly related to a part/s, as indicated by the manual. Just because the manual says, this or that does mean this is the only place the problem can occur. As an example; all bets are off when the supply voltage drops below +12 Vdc. Cross referencing to something else required you go beyond the manual and you are left with BASICS 101, meter, scope, swapping parts, etc. Another change in the acceptor was to use an insulated 5 vdc regulator which does not carry the logic ground to the metal frame of the acceptor. Most of the strange problems had shown up on the CD100-B, C, D juke boxes. One fix is to go to the connector on the CBA-2 jukebox frame. Take a wire jumper, or just tie the Black lead and the green ground wire together. This puts the - side of the power and logic ground to the frame and GROUND. An alternate is to wire center lead of the 5 vdc regulator to the frame of the acceptor module.

What happens after you were at the 'HANDS ON' school or read all of these notes? One of the vendors who was at a

school came in with a CBA-2. He said it seemed fixing it would be more than he could handle and he was short on time. The stacker motor had no screws in it and it was just hanging in the CBA-2. One screw was under the microswitch actuator but the other 2 nuts were missing. The cam was also missing. I proceeded to make my magnetic head test before doing anything and I could not get the magnetic tester into the acceptor. I used the backwards debris mylar card and out came a penny and a dime. I looked at the acceptor and it needed cleaning, lubricated, the belts were bad and the drive motor had a lot of endplay. Then I made my special magnetic head check and it showed the magnetic head was very bad and if all the other work were done, the acceptor would end up with very poor poor acceptance unless it was replaced. Other parts such as belts, shafts, cleaning, Magic Wanding, etc, had to be done to get this acceptor back on line. The serial number was 437911 and the unit had been in someone else's repair shop in Oct 1992.

A vendor called and he noted one of the belts was not moving. He wanted to bring it in and he did. At the Hands On school he had been shown how to take the CBA-2 apart and even showed 2 bad upper drive pulley assemblies and one good one. I had to point out the bad upper pulley slipping on the shaft. This vendor stated he was not ready to start taking the CBA-2s apart and in this case, he had to come in for the part anyway. I was at the session this vendor was at and the school covered everything about the upper pulleys in detail including how to change it. The vendor stated this unit had not gotten much use in the machine (serial # 731703, made Sept 91) but it three years old and never had any lubrication. It was bone dry and I presume this had something to do with the broken upper pulley. It had stickation and must have been rejecting many bills. The forward and reverses were hard on the pulleys because of the hard turning shafts. Note just replacing the shaft pulleys was just the tip of the iceberg because the CBA-2 acceptor was in bad need of cleaning and Magic

Wand lubrication.

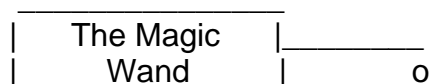

What are you going to do about replacing a broken upper pulley assembly, a bad magnetic head assembly, or lower cell assembly board in case you have a V2 or V3 problem? Do you have the part/s? You will need an upper pulley assembly, Magnetic head assembly, or lower cell assembly (for V2/V3 problems), belts, etc, and just as important, are you able to clean and lubricate the acceptor in order to get the CBAs/UCBAs back on line with a reasonable acceptance range and long term trouble free life? I have put information in these notes based on things I saw. That's why you see a large amount of words dealing with preventive maintenance. Also covered is the operator's lack of knowledge and/or oversight. Most people do not want to read about these things but most of the information in these notes holds the keys to reducing downtime, high repair and exchange costs, major failures and increasing acceptor life and which gets more income into the bill box every week. At one point in these notes I used the term "Vendor denial" after a vendor had trouble with an acceptor after 9 months and this makes my point that partial preventive maintenance and lubrication does not work. While this was a worst case history, it proves that the grace period before damage is shorter than you want to accept and it is affected by the type of the location the acceptor is in. Whatever the case, along with other business pressures of time and money, it appears to me vendor denial is a predominant determinant why the equipment does not get TLC. No matter what, or how much I write, the denial exists for many vendors and while many agree the statements made here may have merit, the result is still partial or non-action. When failures, downtime, repeat service calls, repair and exchange bills, etc, occur, the paradox becomes reality. A dime or something else, found pushed into the acceptor, knife nicks on the tracks, etc, may be the

problem with the acceptor but vendor denial and/or no action is often at the root of the problem.

On the other side of the coin is many vendors have a limited base to work from because they have not had the experience that is needed to lay down a base so they know what is important. Reading these notes or having been at the Hands on School in itself may not be enough to let you know what you should, or have to, do. A case in point is a vendor who was at the school and who had luck repair a few units by replacing the lower cell assembly boards. Lubrication, looking at error blinks, looking at the manual, knowing where switches belong was not important because he never had to think about these things. With no acceptance on a unit he went right to the lower cell assembly but he never bothered to count error blinks which had indicated mag problems. By not asking for the part-by-part number the parts people gave him the wrong cell assembly that he connected into the wrong connector on the module. Then he got real cell problems and he had no idea he plugged the wrong cell assembly in the wrong place. He was totally lost. Once these problems got resolved, we get back to original problem that he should have been working on in the first place. The magnetic head assembly problem was not headwear, cable, or main module. The head assembly had stopped working! It gave no mag signal to the module. The vendor got a magnetic head and he installed it into the unit. However the vendor up to this point had never learned the importance of lubricating the acceptor and he could have done it while the acceptor was on the bench and was all apart. The flow of events meant hours of lost time for two partners, missed appointments that had to be rescheduled, and God knows what else. At some point the acceptor has to be removed and lubricated or else a stickation failures may occur in the near term. The acceptor has been in the field 2 1/2 years without lubrication. At one point, I heard "I do lubricate what I can see." You know I do not think they are going take it out of the machine and do the job right. When

asked if they had oilers, one of them commented they did have some back at the shop. The other fellow did not know about this or ever used them. They had not looked at the lubrication pages and pictures in the manual.

OK, assume they, or you, do not have the base to work from so we have to start with BASICS 101 and meld it with the school and these notes. They, and you, have to go back to the start and remember what you were told at the school and re-read these notes in an attempt to find what did not sink in. Be aware that you will have to pay the price of not doing something correctly or taking short cuts.

BASIC101 says if you want to go somewhere read the signs, look at the map, etc. The status blinks and error reports are the signs and the schools, these notes and the manuals are your maps. They tell you where to go and together they start to lay down a base platform you can work from. Jumping before you leap may not work. The vendor did not look at error codes blinks, did not look up part number, compare old and new lower cell assemblies, did not look at which connector he un-plugged the assembly from, assumed a new part was a good part and it plugged somewhere else. These are all BASICS 101 order of things that you will have to deal with every day of the week. There is nothing hard about simple plain and simple basics. If I said; "Haste makes waste," you understand the principle and if you take time to think about it you could apply the principle to what you do. Not doing the Magic Wand oiling and not ever looking at the manual lubrication pages, could at some point, translate directly to haste makes waste. When working on acceptors how much is important to your base knowledge and what can you forget or put aside? No much! All I can say is; "Good luck with your BASICS 101 and CBAing."

A solid base means looking and comparing all the time. Take nothing for granted. I got a telephone call from a person who has worked on many OBA and CBAs and he

explained he had just replaced a CBA-2 the upper drive pulley assembly. When he went to put on the gear he could get it on the shaft. He then noted the new part was not made correctly. Actually, he had reversed the pulley shaft so on the gear side there was no key way. He could not put the gear on the shaft. This meant he had to do the job all over again but there was another problem. This part was defective and it did not have the flat spot for the gear. I had never saw this problem myself but the story points out a new part may not be a good part. BASICS 101 (and/or Murphy's Law) says you can do a procedure 100 times but on the 101st time something can (and will) go wrong. Be aware of the Law; A new (or same) part may not be the same or be good part.

There may be many things that I do not see so the details never appear in these notes unless I happen to see a vendor do something. The example here is a case where someone wanted to show me the magnetic head on a CBA-2. The lower logic module was already off so he reached in and pulled the pressure roller back as far as it would go, in fact and little more then he should have because the leaf springs holding the pin in place got bent a little bit. I stood there in shock because I saw both springs going to the pressure roller and anticheat lever being stretched. Since I always remove these springs when I have pull the pressure roller back from the head I never thought someone would just reach into the unit and just pull back the pressure roller back without removing the springs first. I have spring hooks and use them all the time. Long before I purchased the commercial spring hooks, I made one and I still use the hand made one for the job. Cleaning the pressure roller is part of routine maintenance so removing the springs and cleaning the pressure roller is a basic procedure to me and should for those doing repair or preventive maintenance. I presume you are good with a long nose or have, and use, spring hooks!

Here is another example; I saw someone

put back the retaining ring that holds the upper pulley gear in place by banging it on without having a metal block on the other end of the shaft. When banging the clip on, the pressure is applied to the pulley on the shaft (side away from the gear) and this pulley can be cracked, broken loose from the shaft and/or pushed out of alignment. The point here is two fold, one is spring or pulley abuse, but the bigger question I have is ; What are other procedures are some vendors using which are harmful to the equipment? Since I do not know what might be, I cannot write about alternates like using spring hooks or putting a metal block under the shaft.

There are some things I can write about because I see the problems or get many phone calls about them. One of the main problems is the service person does not know how to set the switches for a given system or where to put the 2 wire data plug in the wrong connector. Let's cover the 2 wire data cable/plug first. With many systems which use the switches set with 1 3 4 on, (4900 single board, newer juke boxes, Eagle, etc), the CBA-2 or UCBA-2 can be the older version with switches inside and the 2 wire data link plugs into the 2 pin side connector. When the unit is a new version the switches are on the bottom, the cable gets plugged into the connector on the bottom near the reset switch and not the side connector. Another major problem is vendors do not know whereto set the switches, do it wrong, or attempt to set the switches to another mode in order to get the acceptor to work. With the 1 3 4 on and the use of the data 2 wire loop (ROWELINK), the acceptor will not acceptor bills until the main computer tells the acceptor it is ready to accept bills. Depending on the system, this might be when there is enough money to make change, or when everything is operating normal. The CBA-2/UCBA-2 status LED will be "OFF" when the acceptor is ready to accept bills. In some cases, people start playing around with the switches and can get the acceptor to accept a bill but they do not get credit on the unit even if the bill is accepted and stacked.

Some vendors waste many hours exchanging acceptors, modules, and whatever because they make the errors listed above. 2 wire plug in wrong place, use incorrect switch listing, try other switch settings, fail to set the switching correctly (off is on, they used switch 8-1 as position 1-8, etc), so they never get the system back on line. Mis-leading result reports occur when these things happen. "It accepts the bill but I we get no credits. I swapped the logic module and I got the same results, no credits." In one case, the module Rowelink was defective and status LED was on. The module was bad therefore would not operate in 1 3 4 Rowelink mode. They played around with non-valid switch settings and got to the above report, accepted bill but No Credits. When swapping the module, they set the switches wrong and were not on 1 3 4 . They got the same problem but for a different reason, the switches were set wrong. These types problems end up as extended panic, expensive exchanges and/or wasting time. What starts off as a simple problem develops into a living nightmare. Once again, Bruno logic is simple enough, what is the correct setting for a given system and set them correctly, hit reset or power up again, and then try it again. Do no let panic disorder or a mental calamity get in the way of simple basics.

We have already seen problems with the new SBC-2 (Small Bill Changer) which uses a UBA-2 in the same configuration as the 4900 and new Jukeboxes. It uses Rowelink with that small 2 wire cable and the switch setting of 1 3 4 on. The problems have been miss-programming of the main computer and also the operator mis-setting the UBA-2 switches. In one case, the problem was breaking of the small 2 pin connector. Note that these problems have been induced by operator errors. The following was edited from the SBC-2 (Small Bill Changer) notes:
Case 8 > The UCBA-2 keep doing a startup cycle and there was no error message was given on the SBC-2 control unit. According to the service person at the site the unit programming was set correctly, that being, \$10 or \$20 was at 0 coins. When I got the

board and installed it into a SBC-2 the UCBA-2 did keep on doing reset cycle. I then checked the programming:

1 4 2 0 520 10 0 2000

He said the program was ok and \$10 and \$20 was set to pay out 0 coins but when I checked the programing the \$20 pay out really set at 00 coins (2000 and not 20 0). The 00 is 100 coins and not 0 coins. I reset the programing for \$20 pay out for 0 coins: 20 0

Note there is a space then a 0 20 0 and not 2000. In doing the programming of the SBC-2 I had never ran across the 00 and had always programmed the machine to space 0. Not ever seeing the 00 I did not tell the vendor to check and/or program a space 0. The manual does show the space 0 has 20_0. There is no _ on the display, there is just a blank digit with nothing on it.

Operator oversight errors can originate a new problem when simple basics are not observed. Wires near a screw, which you a tightening may pinch, short or even cut the wire/s. This often occurs when working near the lower cell assemblies of a CBA-1 (small Phillips screw) or CBA/UCBA-2 1/4" screw/nut mounting hardware. These types of screw/nut wire type problems can happen almost anywhere even when mounting an acceptor into a machine mounting it on a juke bracket. There are many people who simply do not watch what they are doing and end up not knowing they have created a new problem. I cannot count the number of times I have seen many of these types of problems.

From what I sit, I presume the preventive care and feeding for CBA/UCBAs will not be done by most vendors. I can only recall three vendors who are actually remove each and every CBA/UBA from the equipment to clean and lubricate them once a year. They replace belts and other parts as needed. This is done on a preventive basis and they always do the cleaning and lubrication. Generally, they have spares and rotate the acceptors in and out of the machines. Most of the vendors only take action when failures occur. From what I see, most vendors do

work in failure mode rather than a preventive mode. When the Magic Wand oiler is used on a unit that is already in a failure mode, I call it just an oiler and while you may get the acceptor back on line, there is no Magic, you were just lucky.

I have noted what could be a danger point when someone who has done a little work with CBAs and UCBA-2s starts to make service judgments based on what they perceive to be valid. I have heard presumptions based on erroneous perceptions rather than factual data from people who work with me every day. "The error was 4 blinks so the problem must be the flipper so why check the magnetic head. The acceptor is not that old." What we were looking at this time was an acceptor that was very dirty; it had not been cleaned or lubricated. The next logical question was what effect did all this have on the magnetic head and total acceptor wear. The comment that the acceptor was not that old was not a valid factor since the obvious lack of preventive maintenance lead to brutal wear and tear to this acceptor. In fact, my mag test showed the head was on the down side of acceptance curve. How people can be around acceptors for years and jump to conclusions without seeing what is in front of them boggles my mind. To ask me; "Why do you want to make a mag test "is out in left field some where. Later the same day another co-worker to ask, why make a magnetic head test on that acceptor. If people who are into doing heavy service work 8 hours a day wonder why, what conclusions will people in the field make? At this time, I cannot get into specifics because I do not know what assumptions you will make when working on CBAs and UCBA's. I have addressed, in detail, various aspects of problems you may have and find, the fixes, preventive maintenance and a lot more but the way you attack the problems and fix an acceptor will be executed with your own style (order of doing things) based on your FEK.

What the hell is FEK? Familiarity, Experience, and Knowledge (FEK). When

you turn your back on a process, the result is lack of Experience and Familiarly and therefore Knowledge. If you take action based on what you have read in these notes you may escalate your level FEK. My hope is you are not are in, or will get into, the modus operandi of just doing short-term quick fixes. Collectively these notes were not written from the point of view of short term quick fixes but you may end up using the data provided just to get you back on line without the scrutinizing the long term approaches of repair and preventive maintenance. What I am saying here is there are different FEKs and FEK at some low level is just that. Without an alternate perspective, your FEK may stay casted in stone and may be limited by your own order of things. I hope this is not the case when it comes to you.

Poor or no FEK can be hazardous to the equipment. I'm thinking of a case where a V3 problem existed. You, 3 blinks on the status LED. The acceptor was mounted in and R92 juke box so the frame was removed. The service person was told that the LED and cell should be cleaned and it should be lubricated according to the manual if they had not been lubricating the acceptor. Because they were in a hurry, they assumed they could remove the lower cell assembly and clean the LED and cell without removing the CBA-2 from then frame and then removing the logic module so they get at the clips holding the lower LED/cell assembly in place. You guessed it, they broke the clip attempting to put the assembly back in place. Where does expanded FEK come from. One way is to read these notes, and in the case, not making the same mistake, or do what they did and break the clip and you will gain some very important FEK.. There is another side of FEK that exists in the case. What FEK told this guy he could get the assembly back in place with the module in place. What FEK told him he did not have to read the manual first? His FEK should have told him that if a manual exists and it has section that covers the problem area he should look at it first. I'm sure there are several Basics 101

guidelines which apply to the simple procedure of removing the assembly without breaking the clip on the lower track assembly. In this case the old proverb: "Haste makes waste." FEK is required and it starts by looking at the CBA manual.

My FEK is in the long-term mode most of the time. I do a Magnetic head check when looking at a CBA-2 or UCBA-2 before deciding what action to take. A bad or poor head plus a worn drive motor and many other worn parts means it is time to do a factory exchange. I realize the vendor would rather have a cheap quick fix but that is not possible. I know of cases where the vendor went the cheap fix route and ending up spending a lot of money and time. They soon reached a point where they just gave up and got a new acceptor because they were tired of losing time and money and getting no place. In the case of the bad magnetic head, unless replaced, the problem gets worst with time. You should be able to see that FEK must have a wide overview, and at the same time, be telescoped down to the smallest detail. These notes, for the most part, is my FEK written down so you can gain insight to my FEK. How it relates to your FEK will depend on which parts you use in your daily work. When people read this and other notes like Magic Wanding or people see me Magic Wwanding a CBA-2, or UCBA-2, I generally get this question; How do I know what to oil? The answer is always the same. "Read the manual and look at the pictures because there are a few pages in the manual which tell and show you what to do." If someone has looked at the manual, they would have seen these pages (pictures). This in a nutshell is the key, and if you have not done it, it is the start of expanding your FEK to a much higher level, not only for this topic, but many other topics too. As I say; What is, is!

Some of the information in these notes exists because people have asked questions and/or supplied information feedback to me. I welcome opinions and comments that relate to maintenance and repair of your equipment. As you saw, I do

not hold back information.

May the manual and Wand be with you!

Cleaning Mag Head Pressure Rollers

Rowe has designed a card using paper and thin double sided tape to clean ink, dirt, and other contaminants off the magnetic head pressure rollers. The one sticky side is attached to the paper and when you are ready to use the card remove the protective aper to expose the sticky tape. Then stick the card into the acceptor. While the cards were made for the BA50 acceptor they can be used on all Rowe acceptors (except the RBA-7) and other acceptors. Some aceptorst do not pull the paper into the acceptor so you will have to hand crack the acceptor. People who have seen me work know I always use tape to clean the roller/s under the magnetic head/s.



Rowe Part #
252548-01

Rowe now has a card
for the RBA-7.
Use
252548-03

Bruno

Clean51T.pgs Mar 05, 2005 1T



To join the MAGIC WAND CLUB buy one of NECo's Trinity Oilers or a similar type.

Your dues are:

- 1 Buy an oiler, Trinity, Radio Shack's Lubricator # 64-2301A or Rowe's silicone lubricant 270628-01
- 2 Use it for preventive maintenance.

- Warning -
3 Over lubrication and/or getting oil on the belts voids your membership. More is not always better !

When the oiler is empty you will be a full member in the :

**The
MAGIC
Wand
CLUB !**
Bruno



The Bear does use them !



Rubber and belt cleaning should be done when cleaning and lubricating the acceptor. It should be at least once a year and more often in a dirty location. Do not over use the rubber cleaner ! Apply evenly with a soft cloth until clean. Wipe off all excess including the edges. Re-Grip is a cleaner and revitalizer.

Re-Grip
Rubber
Cleaner

Cleaning Rowe Hoppers and Dry Slick !

What can you use to clean and lubricate Rowe Hoppers and clean coin mechs ? Brushing alone is not good enough. Make a wooden or plastic chisel to clean off the hard dirt on either side of the chain. You can grind or file the end of the hopper brush to make a chisel. The product called Dry/Slick is a very good cleaner when wet and when it dries it leaves a surface film which does not collect dirt. It also lubricates the hopper chain. I do not recommend Dry/Slick use where a build up will cause a serious tightening (such as tight shaft and nylon bearing). There is no problem when used on a Rowe hopper or on the coin mech area where the coin slides.

If you can't get hoppers to work right remember "Bruno" can refurbisher your hopper and fix the rivet problem too. . Generally the cost per hopper is \$80-\$100 if it has normal wear and tear.

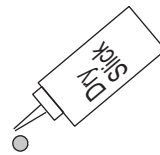

More good stuff !



Using those Cleaning Cards on Rowe Acceptors ?

Rowe original recommended using **denatured alcohol** (paint or hardware store) to clean Rowe bill acceptors so how can you use these cleaning cards? First, let the cards dry and then apply denatured alcohol on the paper to clean the acceptor. After cleaning with a wet card **ALWAYS run a dry card into the acceptor.**

Over kill should be avoided so **do not** use the cards every week, or month, but just when the belts start to get dirty. You can judge time between card use after the first time use by inspecting the amount of dirt picked up on the card.

CBA (1)

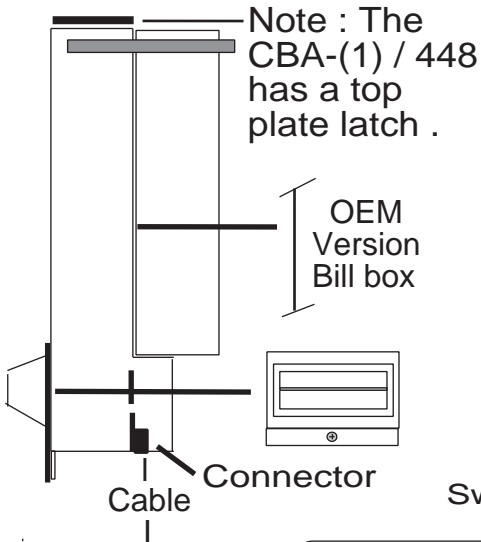

T CBA-2

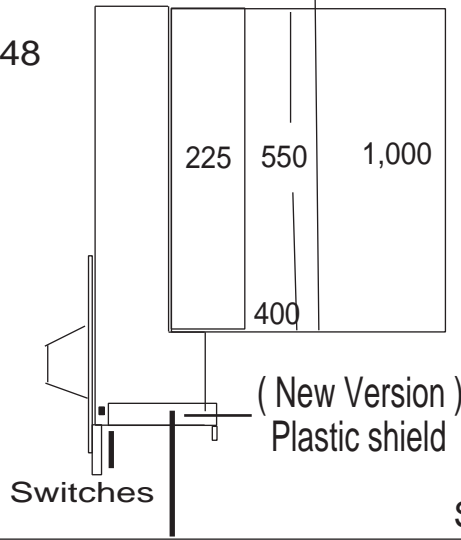

T UCBA-2

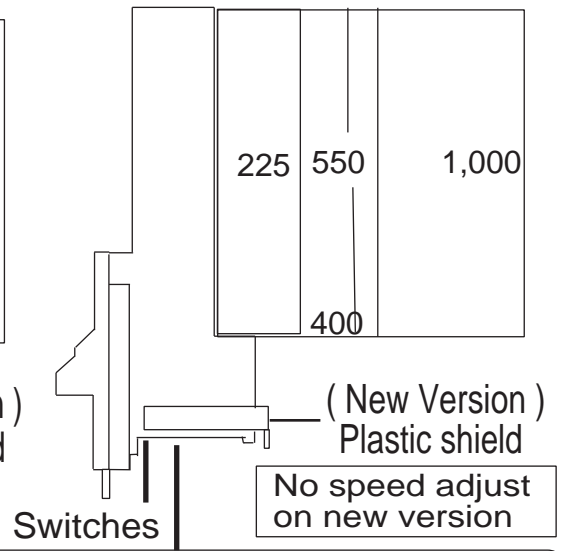

CBA - 1B Control Unit

CD100/CBA-2, 4900- 2 WIRE PLUG - CBA-2 NEW VERSION - USE BOTTOM PLUG , ON OLDER CBA-2S, USE SIDE PLUG. PUT SWITCHES 1 3 4 ON.

448E (BEFORE CBA-2/UBA=2 448/ E2) CBA-1B WITH CONTROL UNIT :
 EARLY 448E 448--4572 / 560433-05
 LATE 488E 448-44502 / 650633-06

SINGLE PRICE VENDING WITH COIN MECH 450679-05/07
 NOSTALGIC JUKE BOX 450679-05 /07 (Some Nostalics use OBA System)
 SPECIAL O E M (AP) VERSION WITH A LARGER - /SIDE OPENING BILL BOX WITH A 450679-03 CONTROL UNIT.

CBA (1)

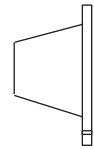

When mounting a CBA-2 in a Juke or wall box, you must use the two metal spacer bars between the CBA-2 and the frame.

Part # 309292-01
(2 required)

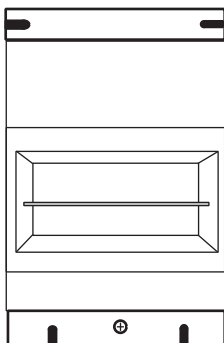
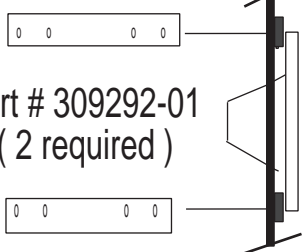

CBA-2 INLET

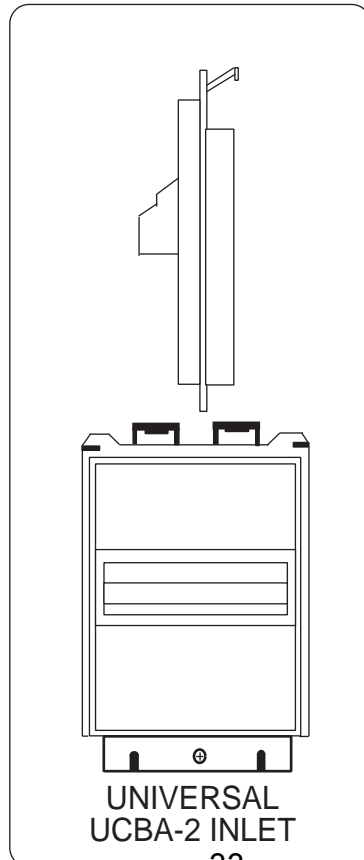

UNIVERSAL UCBA-2 INLET

The term CBA alone does not describe what type of CBA you have or need !

NV CBA-2 and UCBA-2s are show here, but you may have CBA-2/UBA-2 without the plastic shield and the upside-down board.

The label may indicate CBA-2 but it might really be a UCBA-2



At least once a year



JAn 7, 2002 1M CBA s
CBA2UBA .ps

CBA-2

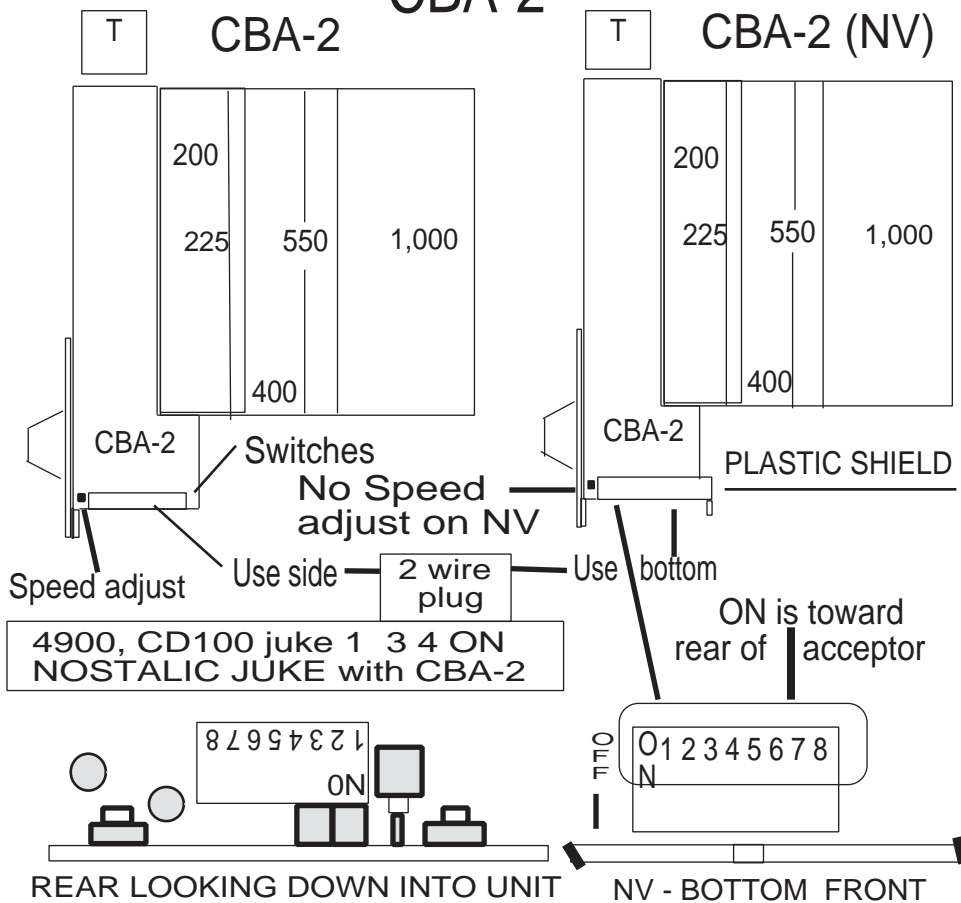

When mounting a CBA-2 in a Juke or wall box, you must use the two metal spacer bars between the CBA-2 and the frame.

Part # 309292-01 (2 required)

CBA-2 INLET

The COINCO version of CBA-2 IS A \$1 ONLY ACCEPTOR.

T SPECIAL COINCO TRANSFORMER SUPPLY B00319-72
 Jones Plug

NORMALLY IT HAS NO SWITCHES BUT.... IF IT HAS SWITCHES, SOME WILL NOT WORK IN THE 1 2 3 4 TEST MODE UNLESS IT IS CONNECTED TO A COIN MECH. IT MAY HAVE NORMAL COINCO OR NEW VERSION Coinco -01 MODULE.

\$5.00 updates:

Old version: Switches inside: 270398-04 kit/w harness

New version: Switches on bottom 651003-01 PCB & bracket

CBA - 2 Normal CBA - 2
 NV New version , Switches on bottom, + plastic shield
 NV Kit -01= Coinco \$1 only. -02 = Normal CBA-2
 T Transformer Power supply
 CBA-2 Coinco version with:
 TC Transformer Power Supply (Special Coinco version)

1 3 4 ON	CD100 C,D etc	NOSTALIC with CBA-2
1 3 4 ON	4900 SR # 21240 - 26144	JR # 09398 - 13967
1 2 3 4 ON	TEST R92, 93, 94	WALL BOX SOME GAMES
	R92-94 - Do not use locking bill box	
ALL OFF	448E2 # 33078 - 42723	(200 bill box)
ALL OFF	406Z # 31006 - 35644	
ALL OFF	408 487 425 # 05510 - 07816	

>>> ALWAYS WRITE DOWN SWITCH SETTINGS! <<<

THE MAGIC WAND!

At least once a year

BRUNO

CBA - 2
 Jan 6, 2002 1M

UCBA-2

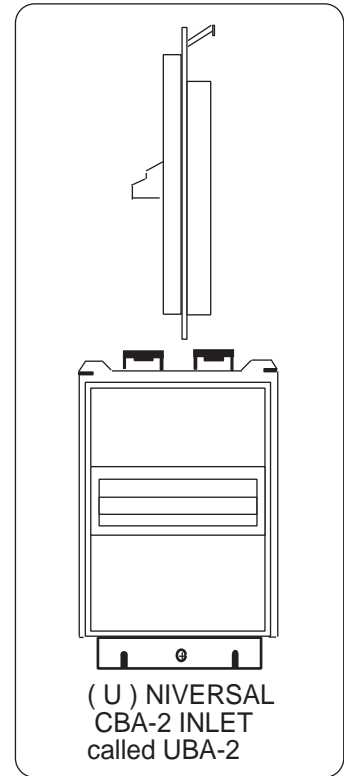
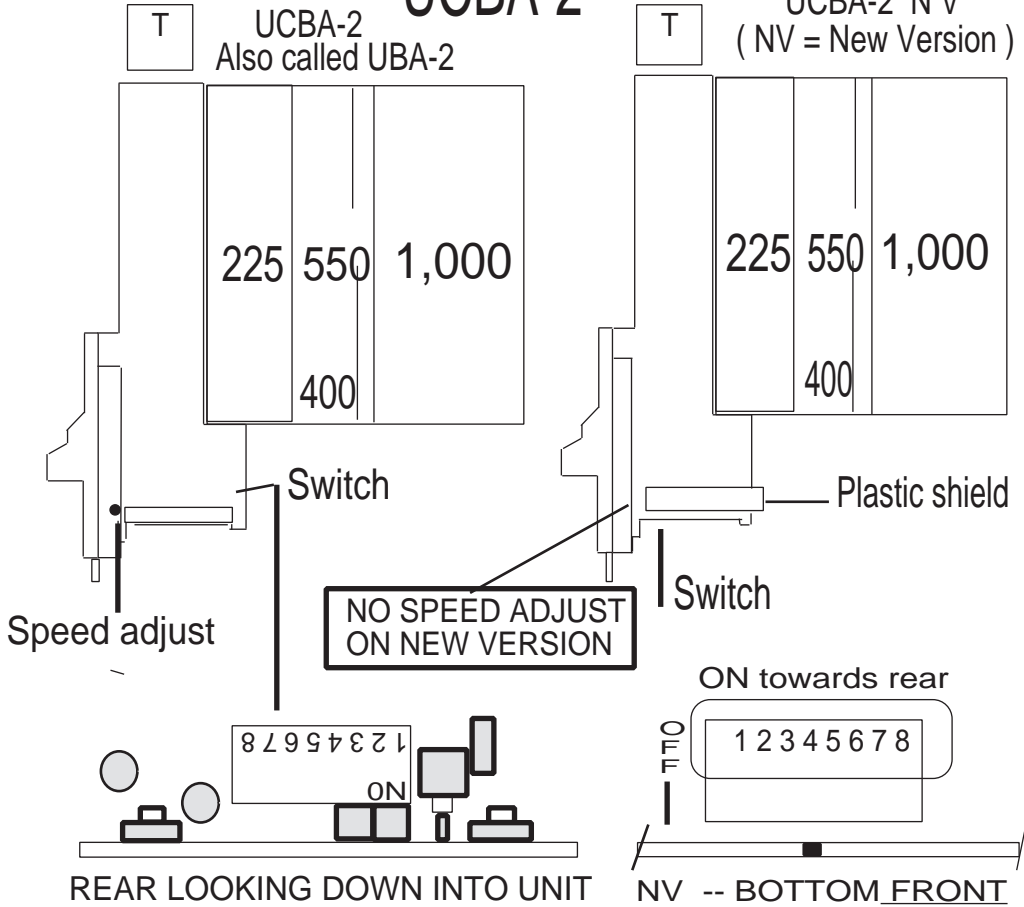

UCBA -2	Universal CBA - 2 [UCBA-2 or UBA-2]
NV	New version Switches on bottom, + plastic shield
T	Transformer Power supply

\$5.00 updates:
 Old version: Switches inside: 270398-05 kit/w harness
 New version: Switches on bottom 651003-02 PCB & bracket

The label on the side of this unit is normally CBA-2 and UNIVERSAL or UCBA-2 does not appear on the label.
 Often " UBA " is used to avoid confusion between the original CBA-2 and the UNVERiSAL CBA-2 shown here. There is the normal UCBA-2 and the New Version UCBA-2.

- 1 3 4 ON 4900 SR # 26145 -> JR # 13968 ->
- 1 3 4 ON SPC-2
- 1 2 3 4 ON TEST SOME GAMES
- ALL OFF 448E2 # 42724 ->
- ALL OFF 406Z # 35645 ->
- ALL OFF 425 # 07817 ->
- ALL OFF EARLY 5900 Ver < 4 software
- 2 ON LATE 5900 Ver ~> 4 software
- ALL OFF 5950
- ALL OFF 548
- ALL OFF 648
- 2 6 7 ON Full Court Frenz II, some pool tables

>>> ALWAYS WRITE DOWN SWITCH SETTINGS <<<



UCBA-2

Cbau-2
 Jan 7, 2002 1Q

CBA, CBA-2 and UCBA-2 V1, V2, V3 and V4 LEDs and Cells + STATUS Error reports

Many CBA-2 UCBA-2 problems are LED and photo cell related. V1 and V4 are typical LED-CELL arrangements. The V2,V3 LED provides the light for V2 cell which reads reflected light from the back of the bill. V3 mounted in the head assembly reads the light passing thru the bill. Remove the logic module so you can see and/or remove the lower cell assembly to clean or replace it. When removing the lower cell assembly you may break the plastic clip holding the assembly. Read the book FIRST ! When you get it off clean LEDs and cells. You can now see the hole and the V3 cell. You may find debris blocking the light path. Since all 3 LEDs and V2,V4 cells are part of the lower cell assembly if you replace it you may fix a V2, V4, and V1 LED and V3 LED problems.. The lower cell assembly addresses problems of five of the seven LED-Cell devices. The old version module has speed plus cell adjustment controls so read the manual. LED/Cell problems could be located in the logic module and we do find broken wires, loose or bad connectors and connection problems. Many times the problem is dirt, debris plus LEDs and photo cells do go bad.

A fault may not showup all of the time. It may depend on time on-off and temperature. Turning the unit off/on or hitting reset without first looking at, and counting the STATUS blinks means we, have no idea which problem occurred. It might be a LED, cell, stacker, etc, problem. Sometimes you need a mirror to see that STATUS indicator before you do anything. Better get one. If you did not count the blinks, a power on/off may fix the problem for X hours, days or weeks but sooner, or later, the problem re-occur. It may take several calls before you decide to count the blinks. Exchanging the acceptor may be expensive because these are factory exchanges not repairs. Sending it in for repair may not get the problem fixed if it does not show up on the bench. Without a blink report there may nothing to look at or fix. You may get it back marked tested Ok. In one case, the vendor told me he had a problem and turning off the power would fix it. Then in a day or two it would not work. I asked what the error was and he said he was never told to look at it. I asked him to get a mirror and count the blinks before doing anything. He found 3 blinks when he got there. I asked he cleaned and lubricated the acceptor every year and he said it had never been cleaned or lubricated. He asked what he could do. I said read the manual to get data on how to clean and lubricate it, remove the lower cell assembly and clean LEDs and cells. Look for debris and if he wanted to shot gun it put in a new lower cell assembly. He said " I'll bring it in ." Since he had the error report we could clean and lubricate the acceptor, look for the problem and may be shot gun it with a new lower assembly. Chances are a problems may not show up on the bench so we need to know the number of STATUS blinks or is it steady on or off..

Getting the error report from the field is also important when a bill gets rejected. As the bill is rejected just leave it there and the count the status blinks which will only appear one time. This will tell you why it got rejected. Status blink reports are very important. I'm writing this today because today I had to fix a v3 problem which was debris (paper) blocking the V3 cell. The guy said " I could have done that if I took it apart ! " That's right if you looked at the error blinks, learned how to open up the acceptor then take off the cell assembly without breaking the clips. Have you looked at the manual ?

No matter what, you and I, need that error/status report ! If you think we can always see the problem on the bench, forget it. At some time, place, and expense you come to know this. If you do a power on/off/on or reset it may only fix the problem til you a get call it don't work (again) or you may find the bill box empty. We may not be able to find and fix the problem without that blinking error report. There are two set of blinks, when just standing there and another set when the bills are rejected. I hate to be a "I told you kinda guy," but Bruno the Bear just did !

If you are going to try to fix some of this stuff make sure you can remove the module and the lower cell assembly without breaking anything. Look at the manual first.

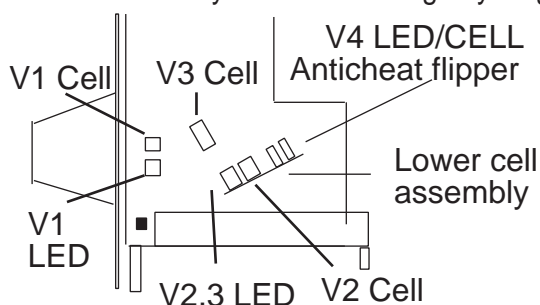

May the error blinks report be with you and the equipment !

You have a mirror in the tool box so you can see the status indicator, Right ?



Bruno The Bear

CBA234.PS Jan 8, 2002 1E

T CBA/UCBA-2

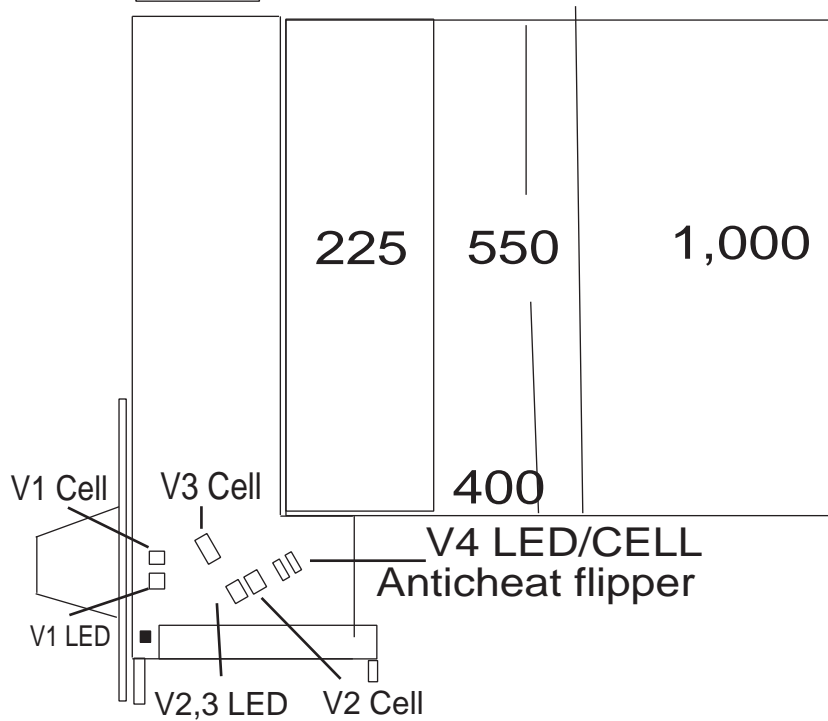

V1 LED is on the bottom and hits V1 cell on the top. The V2,V3 LED is mounted on the lower cell assembly board and supplies light to V3 cell mounting in the Mag head assembly. This same LED supplies the light which is reflected from the back side of the bill to the V2 cell mounted the lower cell assembly board. Errors or problem will be noticed with the number of status blinks

THE MAGIC WAND !

At least once a year

BRUNO











U/CBA 2 Cells
Jan 12, 2002 1D

CBA2cell.ps

Do new \$5 [] Already done [] No []

[] RBA-7 [] CBA-2 [] UBA-2 [] Coinco Original [] NV [] Yes
 [] Tjuke [] Tcounter [] Tcoinco [] T [] None
 [] R92bkt [] R92bent [] No Spacers [] CD 100C/D [] E [] F
 [] CDRN [] MMCD1-3 [] Eagle
 [] cable [] 4900 [] 488E2 [] Juke [] Game [] Other _____
 [] 225 [] 450 [] 1000 [] Latching
 [] Exch add transformer Sw 1 2 3 4 5 6 7 8 _____

Type _____ Mod W B _____ Serial # _____

- B0030688 Spacer for front shaft/rollers o
- B0030715 Power supply & harness assembly,120 vac
- B0031924 Pin for lower large black roller □
- B0031930 Shaft (Front flat roller) —
- B0031933 Gear, Larger upper reduction @
- B0031936 Gear, small reduction ⊙
- B0031937 Pin for upper flat takeup □
- B0031944 Retaining ring for drive gear ⊙
- B0031946 *Belt,Timing Drive 
- B0031955 Lower track 
- B0031956 *Belt,Flat 
- B0031975 Top plate and latch 
- B0031980 Upper harness and cell assembly
- 40791206 Motor assy for stacker +mi 
- 45069002 Long-short Lower harness & cell assembly
- 25223201 Spring - for anitcheat Yellow -W-
- 25223301 Spring - for anitcheat Blue -W-
- 27038901 Shaft Upper Front pulley drive assy 
- 25244101 Shaft assy Upper drive assy 
- 25225501 Crowned roller little top +
-
- 65100301 CBA-2 NV \$5 update module
- 65100302 UBA-2 NV \$5 update module
- 30929201 Spacer bar for R92-4, CD-100 frame
- 35094601 Roller Lower large drum pulley ⊙
- 35117001 Pressure roller assembly o ⊙
- 40823701 Power supply for CBA-2 in R-92 junkbox
- 45073506 Lower long harness and cell assembly 
- 45058607 Motor assy for drive belts 
- 65070704 Track upper assembly with Mag head 
- 45069002 B0030824 Upper harness 45= long B00 short
-
- 25096105 Foam block 225 E
- B0030702 Foam block 450 E



**CBA-2 / UCBA-2 TYPICAL GAME OR POOL TABLE (\$1 and \$5 ACCEPT)
AND USING B00307-38 INTERFACE CABLE plus other data**

Switches 6 and 7 set output pulse, each add 100 msec. With 6 and 7 off output pulse = 30 msec.

NOTE: Corrected drawing Jan 25, 1996
Previous were incorrect !!!!

Typical switch settings 2 3 4 7 ON

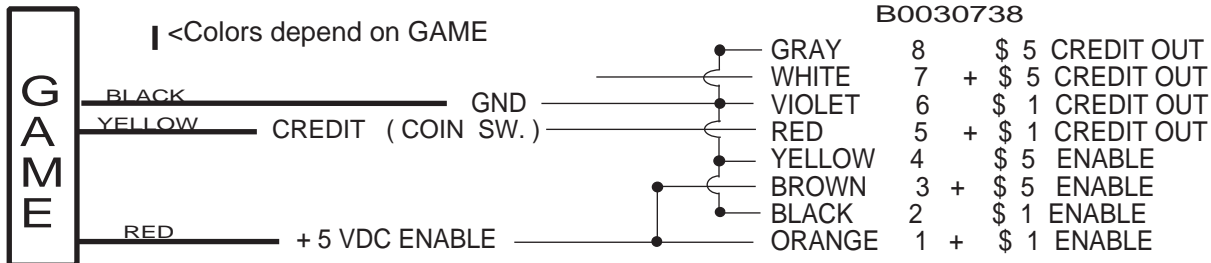

For any given interface for a CBA-2/UCBA-2 it is best to look at the manual. Interface. Switch settings vary a great deal. This interface is just one of many interfaces. This interface uses ROWE's 8 wire cable plugged into P3.

Some systems take the DC voltage for the CBA-2/UCBA-2 from the existing system rather than a ROWE transformer power supply. The DC voltage must be at least 12 vdc (under load - motor running) at the acceptor for a proper acceptance range. Some power supplies are not regulated, wires are too small, poor connections exist, or the line voltage drops from things like brown outs or when a smoke eater comes on than the acceptance drops off or has no accept. The voltage must be measured when the acceptance problem exists and/or use a meter with a MAX-MIN HOLD feature.

Full Court Frenz II with UCBA-2: Switch settings = 2 6 7 on.

The voltage of 11.5 vdc is too low. Use the Rowe power supply transformer (Part number 4-08231-01) or [other > 12 vdc supply] and put into the system. Pick up the AC after the fuse and switch. At the UCBA-2 DC power plug, cut the Red +11.5 volt wire and tie the new power supply (+) red wire into the UCBA-2. Splice in the (-) side by peeling back some insulation on the black wire near the UCBA-2 and slice the black (-) of the Rowe transformer or power supply to the existing black (-) side of the Frenz II system. Use large gauge wire for power connections to reduce the IR drop in the wire. With motors running the current is quite large. Small gauge will not work.

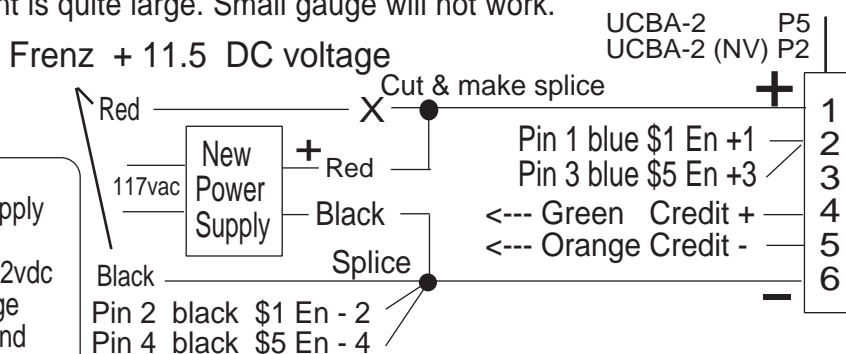

New power supply:
Rowe CBA power supply
or a small switching
supply with only the 12vdc
is used turn up voltage
adjust to get 13vdc and
use large gauge wires.

Alternate cable
for \$1, \$5 Enables
Part # B00307-38

Pin 1 Orange
Pin 2 Black
Pin 3 Brown
Pin 4 Yellow
Pins 5-8 not used

Typical Crane interface

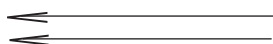

GRAY	8		
WHITE	7		
VIOLET	6	-	CREDIT OUT
RED	5	+	CREDIT OUT
YELLOW	4	-	\$ 5 ENABLE
BROWN	3	+	\$ 5 ENABLE
BLACK	2	-	\$ 1 ENABLE
ORANGE	1	+	\$ 1 ENABLE

Typical switch settings = 1 2 3 4 ON

P3 CABLE PART #
B0030738



CBA_GAM1N.ps
Jan 6, 2002 1 N

CBA-4 Interfacing

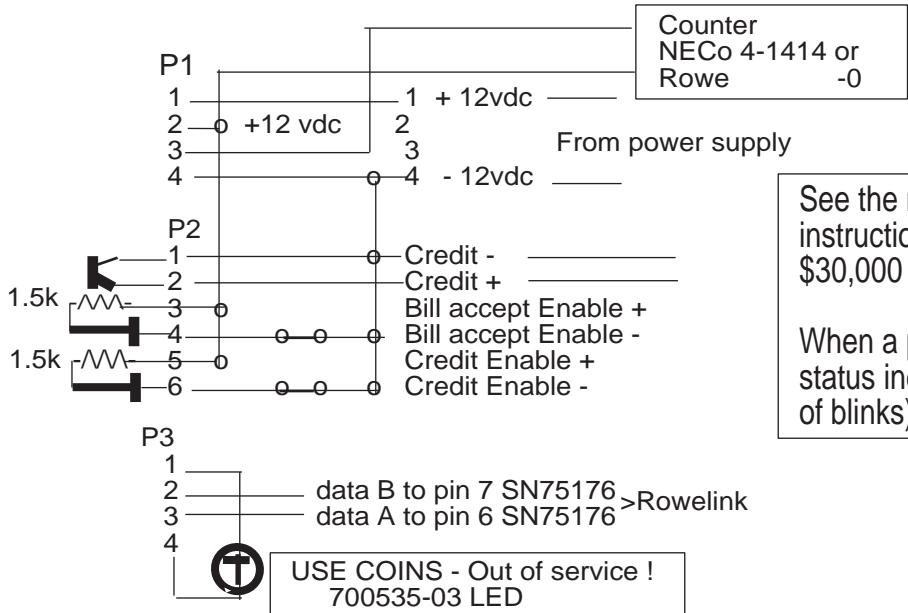

See the manual for cleaning and lubrication instructions. Clean and lube the CBA-4 every \$30,000 or at least once a year.

When a problem occurs always record the status indication (On,Off, or type and number of blinks). See the manual.

Credit pulse

50	50	none	f
100	100	2	
60	300	1	
200	200	1,2	
			ms

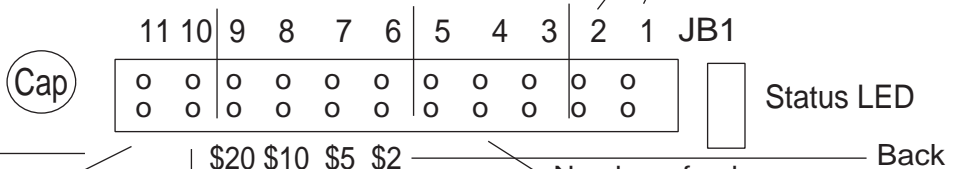

None: f
 No External credit enable P7 5,6 required
 Yes = enable required.

None: f
 No External Bill accept enable P7 3,4 required
 Yes = enable required.

Number of pulses

none	1	2	4	10	20
5	2	4	10	20	40
4	3	6	15	30	60
4,5	4	8	20	40	80
3	10	20	50	100	200
3,5	10	20	60	120	240
3,4	20	50	140	290	590
3,4,5	20	40	100	200	400

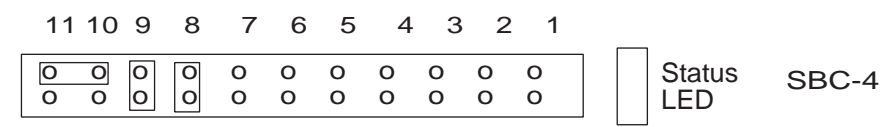
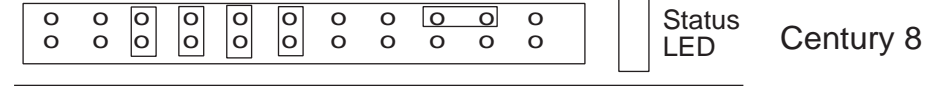
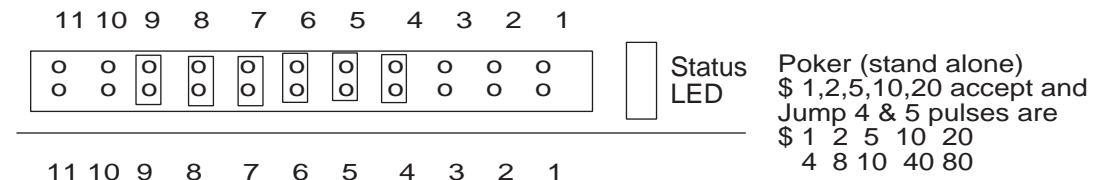
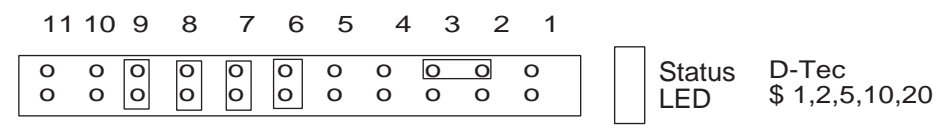
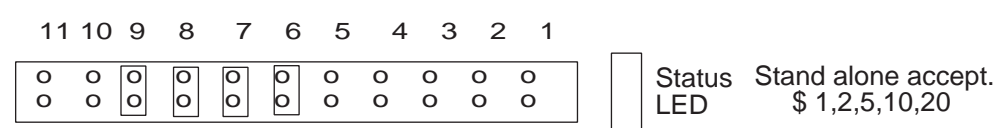
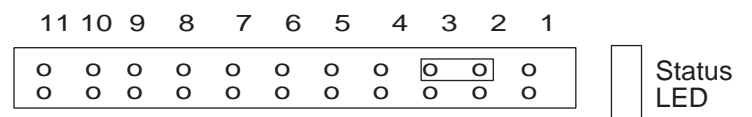

01 [Bear facts on debris stuck inside a CBA or UCBA Acceptor] by Bruno D Puglia August 06, 1993

Problems can occur when debris or parts of bills get stuck inside the acceptor. Debris or bill removal is NOT a warranty item. Some one may attack the problem by using anything they can get their hands on. All to often the TOOL is sharp, or pointed and two things can happen when the tool is used. It may be large compared the opening and the acceptor opening is deformed and left open. This effects the way the bill is pulled into the acceptor. In addition, the tracks are nicked or cut by the sharp tool may damage the lower and/or lower tracks and they have to be replaced. Remember, the upper assembly contains the mag head and the mag amp so it is quite expensive. How does a person handle debris stuck in the acceptor ?

The simplest way to remove junk is to use a semi-stiff piece of mylar or plastic about .020 thick. For those who want to save a few bucks, cut a mylar strip so it just fits in the space between the belts and long enough to reach from the back of the acceptor all the way to the front inlet. To get junk out of the acceptor, kill the power to the acceptor, then open the bill box. We are going implant the strip in the back and push the debris out the front. <KEEP READING>! YOU MUST pull, or push, the anticheat lever so the strip can be inserted into the track openings in the rear. Slowly push the strip and pray what ever is inside the tracks comes out the front. If some thing is stuck on the edges of the tracks you may have to repeat the process but this time, insert the mylar between the two belts. You may have to do the left, right, or both sides. You must get the anticheat level out of the way before pushing the strip into the tracks. Another option is removing the acceptor and then remove the logic module and maybe the cover on the bottom. This will gain you access to the cell assembly board. READ the manual on how to remove this sensor board otherwise you can mutilate the lower track clips which hold the cell assembly board. If clip breaks you have to replace the lower track. Once the sensor board is removed, you see the hole for the V3 cell sensor and you might see the debris. You may be able to remove it. A much larger hole is under the head pressure roller. DO NOT pull back the pressure roller assembly because this will deform two springs. Remove both springs and the pressure roller can be moved out of the way to a point. Do not pull back to far because you can deform the the pressure roller assembly holding lever spring. Pulling the roller assembly slightly will expose the hole and the magneti head. If Murphy's law has been repealed, you may be able to pull out the debris in tthe acceptor.

The mylar or plastic strip procedure presumes the tracks has not been damaged by sharp objects. If a worst case condition exists and you cannot get the tracks clear, the acceptor has to come apart. I hope you have a spare ! The mylar strip I use is actually a old juke box label strip. They are no longer available but we have a few left. Part # 3-65271-01. An alternative might be a plastic book marker sold in some book stores. You want to end up with a .020 thick strip which is about 1 5/8" wide and 7 1/2" long. You can make your own strip.

A Magic Wand Card for removing debris in a CBA - UCBA acceptors.

Plastic or Mylar strip .020 thick



As a side note, I have found that most acceptors with debris inside are in need of cleaning and lubrication. You may not have time to do preventive maintenance and if that is true you have to realize two things. When damage occurs you risk the risk of higher repair bills and even if you get the debris out of the acceptor, and it is not damaged the root problem of the ack of cleaning and lubrication (stickation) may still exist.

CBACARD1D.pgs July 28, 1995 1C

**CBA/UCBA-2/4 and RBA-7 Lubrication
Every \$30,000 or once a year !**

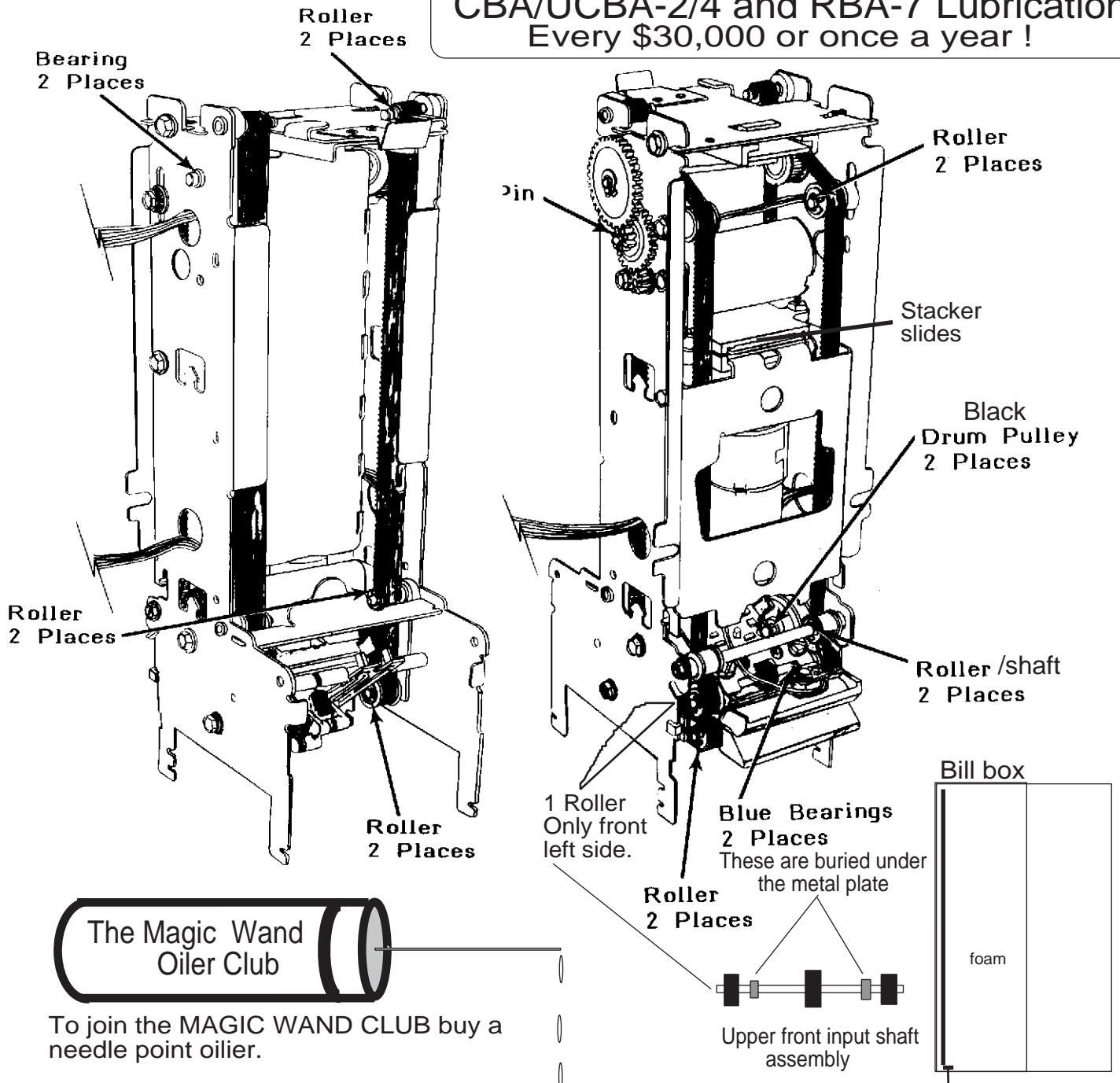

To join the MAGIC WAND CLUB buy a needle point oilier.

Your membership requirements are :

- 1 Buy an oilier; Trinity oilier, Radio Shack's lubricator # 64-2301A or Rowe's silicone lubricant 270628-01
- 2 Use it for preventive maintenance. Every \$30,000 or once a year which ever comes first !

- Warning -

3 Over lubrication and/or getting oil on the belts voids your membership. More is not always better !

When the oilier is empty you will be a full member in the :



Bottom of pressure plate..
Get rid of that squeak !

**The
Magic
Wand
Club!**



Bruno
CBAULUBE.PGS
Feb 16, 2005 2B

Rowe CBA-1 and 4-50679-0x [05] CCU.
 Vending OEM
 Early Nostalgic
 Juke boxes.
 Bruno Puglia
 East Coast Amusements, Braintree MA

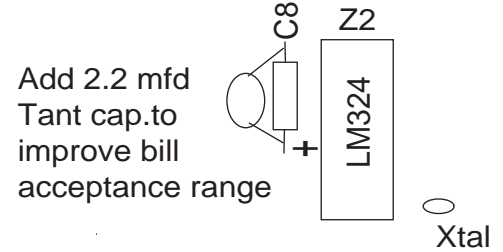
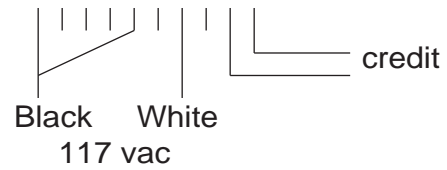

The CBA-1 should be in good shape and lubricated. Since the CBA-1 is similar to the CBA-2 look at the lubrication Bear note for instructions for lubing the CBAs.

You should remove the control unit's cover and check if the improve the bill acceptance range mod has been made. A 2.2 mfd Tantumn cap is added across C8 or the value of C8 is 2.2 mfd. If the 2.2 mfd cap is not there tack a 2.2 mfd cap across C8. Note the + end. If the cap is there, or you installed it, tag the outside so you know the 2.2 update mod has been done.

Before replacing the cover notice the speed adjustment pot on the left side of the lower board and the mag adjust pot behind the C28 cap. Refer to the Speed/Mag gain Bear note page for the adjust procedure information.

Additional information can be found in my other Bear notes

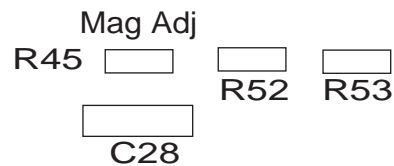
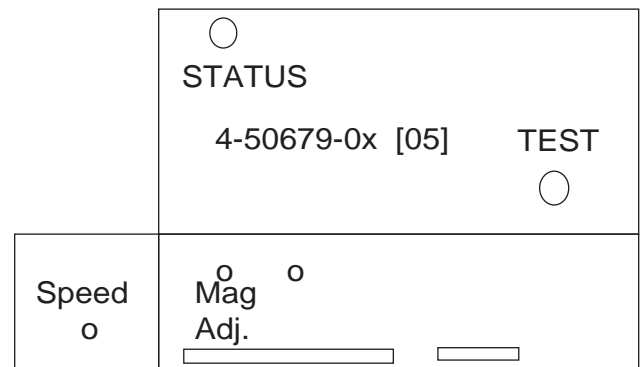

Xerox/copy onto heavy #24 paper or light cardboard.
 When storing an acceptor roll the paper strip
 into the acceptor.

Location: _____
 Date: __ __, 2005
 From EQ: _____
 Type Acc.: _____
 Serial#: _____
 Error: _____
 Problem: _____

Location: _____
 Date: __ __, 2005
 From EQ: _____
 Type Acc.: _____
 Serial#: _____
 Error: _____
 Problem: _____

Location: _____
 Date: __ __, 2005
 From EQ: _____
 Type Acc.: _____
 Serial#: _____
 Error: _____
 Problem: _____

When removing an acceptor for repair please note why it was removed and what unit it came from. Please note any error message, error code, or status blinks. In the picture below the dark stuff on the head came from the pressure roller. Never leave the mag head pressure wet [after using wet cleaning card]. Never store the acceptor without inserting a piece of white paper between the magnetic head and the pressure roller. High temperature in a hot storage area can increase the transfer of the rubber to the mag head.

When removing an acceptor for repair please note why it was removed and what unit it came from. Please note any error message, error code, or status blinks. In the picture below the dark stuff on the head came from the pressure roller. Never leave the mag head pressure wet [after using wet cleaning card]. Never store the acceptor without inserting a piece of white paper between the magnetic head and the pressure roller. High temperature in a hot storage area can increase the transfer of the rubber to the mag head.

When removing an acceptor for repair please note why it was removed and what unit it came from. Please note any error message, error code, or status blinks. In the picture below the dark stuff on the head came from the pressure roller. Never leave the mag head pressure wet [after using wet cleaning card]. Never store the acceptor without inserting a piece of white paper between the magnetic head and the pressure roller. High temperature in a hot storage area can increase the transfer of the rubber to the mag head.

Another Bear note from Bruno !

Another Bear note from Bruno !

Another Bear note from Bruno !

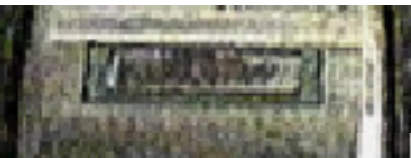

At some point in time you may want to check out my other Bear notebook articles because they contain a great deal of related material. You will find them on Bruno's Page in <http://www.eastcoastamusements.com/> then: left click on: **Visit his page for service notes and tips.** **OR:** <http://www.eastcoastamusements.com/services.htm> and then click on the BEAR with the flower!!

Note: These files were checked with Acrobat Reader 7.0. Earlier versions **may not** view/print correctly. I know version 5.0 will not work correctly.

If you click on that tile name and if your computer is loaded with the Adobe reader the file this will open up an Adobe window. If you want to save the Bear Notes .pdf file/s from the Bruno page you can right click on the article title and a window will appear on the screen. One of the selections will be Save Target As. Left click on it and a Save As box will appear and you can select where you want to save the .pdf file. You can save the file on your own computer.

You will want to check the East Coast Amusements site for revised or new articles. I do have more titles in the works. Here are some the posted articles.

ROWE 4900 ACCEPTOR ISSUES
ROWE BC-1 BILL CHANGER
THE MAGIC WAND (Dick's - my favorite)!
CONNECTORS - FIXING AND TESTING (another good one)
ROWE BILL CHANGER HOPPER REPAIR
MEASURING VOLTAGES
BUCKET POWER ON ERRORS
ROWE STACKERS
MAG HEAD LOOP SECRETS
DREMEL & ROWE STUFF
FEK MOTOR TEST UNIT
OBA ACCEPTORS
JACKPOTTING, FS, BUCKET POWER ON & CRASHES
BC-8 to BC-35 Bill Changers
CBA_UCBA
Basics_101
BCxx00_bill_changers

If you have trouble printing some Acrobat drawing pdf pages:
Adobe Acrobat printing of some drawn picture pages correctly may require using Acrobat printer setup and setting Print to image on.

Please take note that East Coast Amusements is supplying the Bear Note pages on their web site for you and for me at their expense. I just write and East Coast Amusements does all the rest.

To East Coast Amusements
> THANKS ! Bruno

1F